



ODU

**Department of Electrical &
Computer Engineering**

ECE 481W SENIOR DESIGN PROJECTS

INNOVATING THE FUTURE IS WHAT WE DO

SPRING 2026

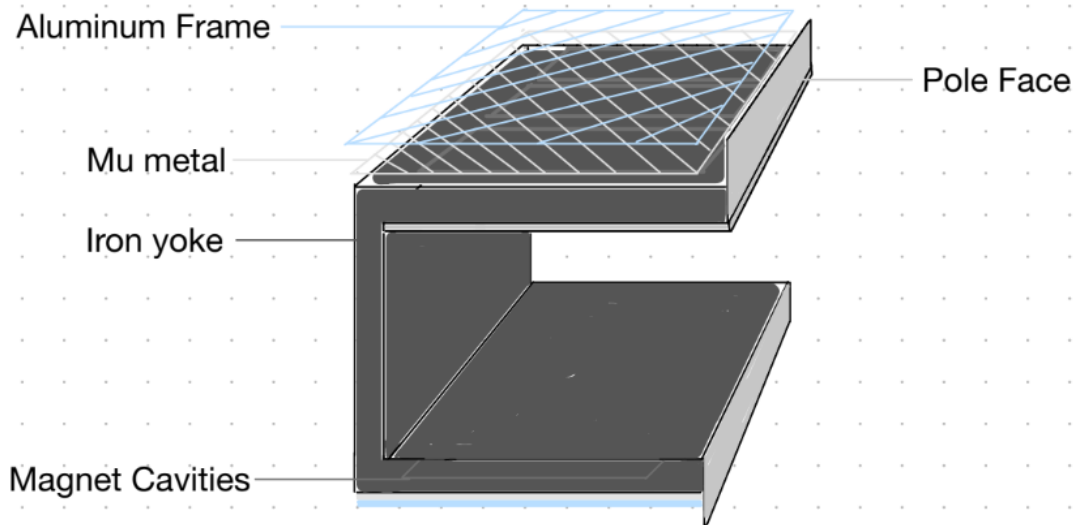
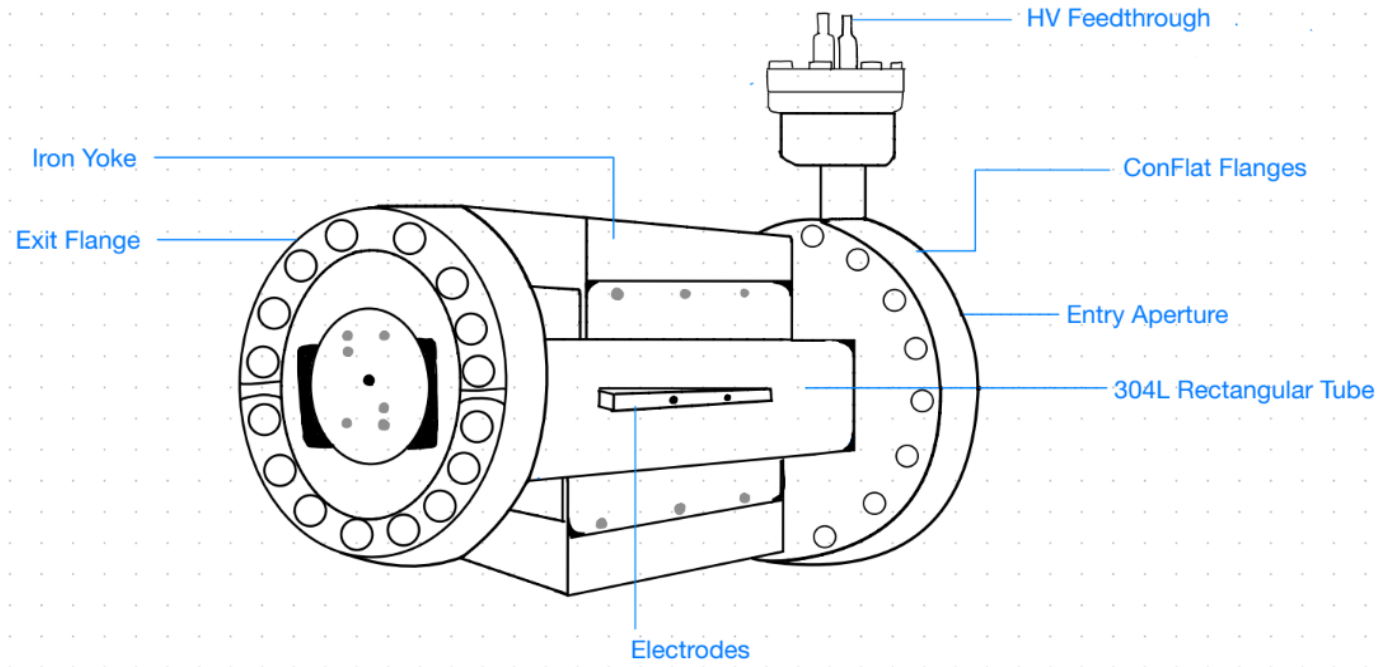

Design of a Wien Velocity Filter for Niobium 7+ Charge Ions

National Science Foundation

This project's goal is to design, build, and test a Wien velocity filter capable of selecting Niobium 7+ ions. This filter uses orthogonal electric and magnetic fields to isolate ions traveling at a specific velocity.

Team Members: Nicolas Paul, Andrew Short, Mya Watson

Advisor: Dr. Hani E. Elsayed-Ali

Design Challenge

Design and construct a compact Wien velocity filter to provide uniform electric and magnetic fields to selectively transmit Niobium 7+ charge ions.

Design Goals

- Achieve precise ion beam selection
- Produce stable crossed E and B fields
- Ensure safe and reliable operation

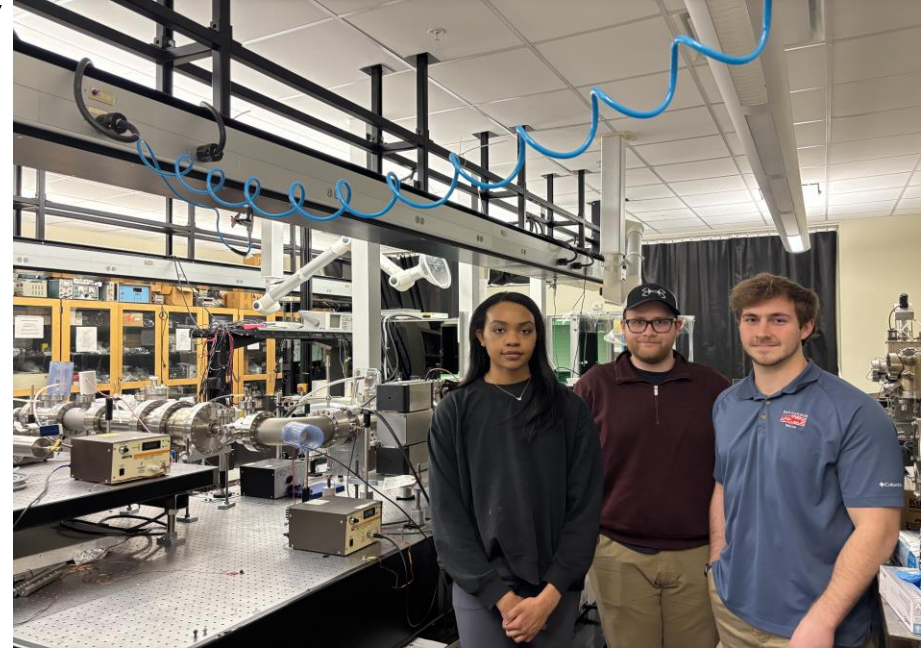

"Scientists investigate that which already is; engineers create that which has never been." — Albert Einstein.







Department of Electrical &
Computer Engineering

Small-Scale Self-Driving RC Vehicle

The project goal is to design, build, test, and improve a small-scale AI self-driving vehicle on an RC car-based platform. Hardware and software integration along with machine learning will be used to construct a vehicle that can redirect itself to avoid unexpected obstacles on a track.

Team Members *Scott Graham, Madison Hancock*

Advisor: *Dr. Hicham Chaoui*

Design Challenge

Design and Build an Autonomous RC Vehicle

Design Goals

- Integrate 3D printed and RC hardware to build a compact vehicle
- Develop software for data acquisition and perception
- Validate vehicle on a track with various obstacles

**“Small-Scale AI vehicles will trailblaze a path for larger AI implementation in everyday life.
- Scott Graham”**

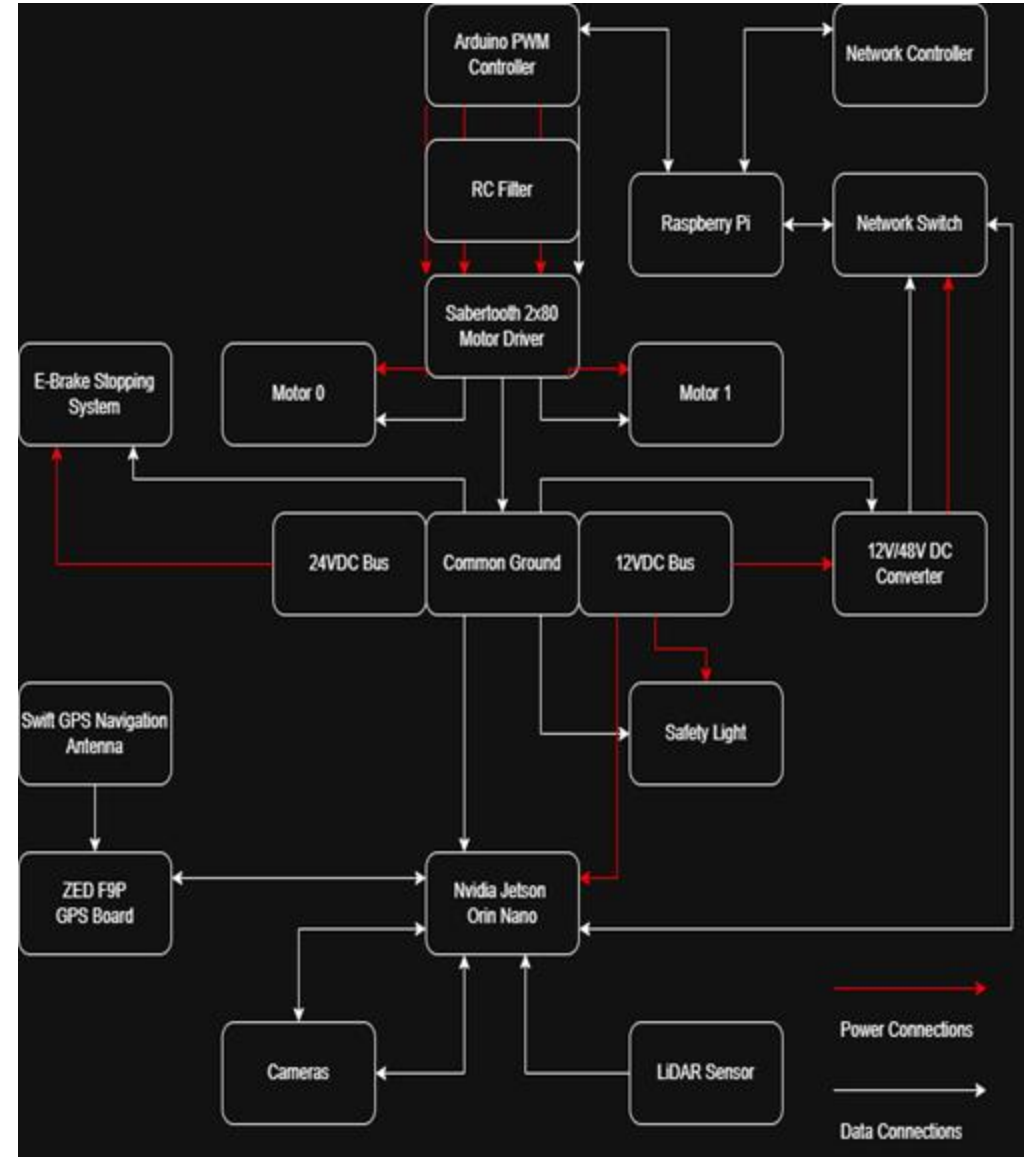

Intelligent Ground Vehicle

Funding Agency: ODU ECE Department

The design and creation of a self-navigating autonomous vehicle capable of handling the Intelligent Ground Vehicle Competition (IGVC) obstacle course.

Team Members : *Mariah Hancock, Kokou Moutchou, Rodel Sison*

Advisor: *Dr. Lee Belfore*

Design Challenge

Iterate and Upgrade the Little Blue vehicle for the 2026 IGV Competition.

Design Goals

- *Work with the 482 & Online Teams to install critical components for reading direct build velocity*
- *Identify & Implement ways to reduce/eliminate electrical brownouts during E-stop usage*
- *Consolidate & Incorporate a single battery system to reduce unreliability and maintain Quality of Life*
- *Maintain Design within the 2026 IGVC Constraints and Regulations*



“

**“Teamwork always wins.”
- Kokou, Mariah, Rodel**

”

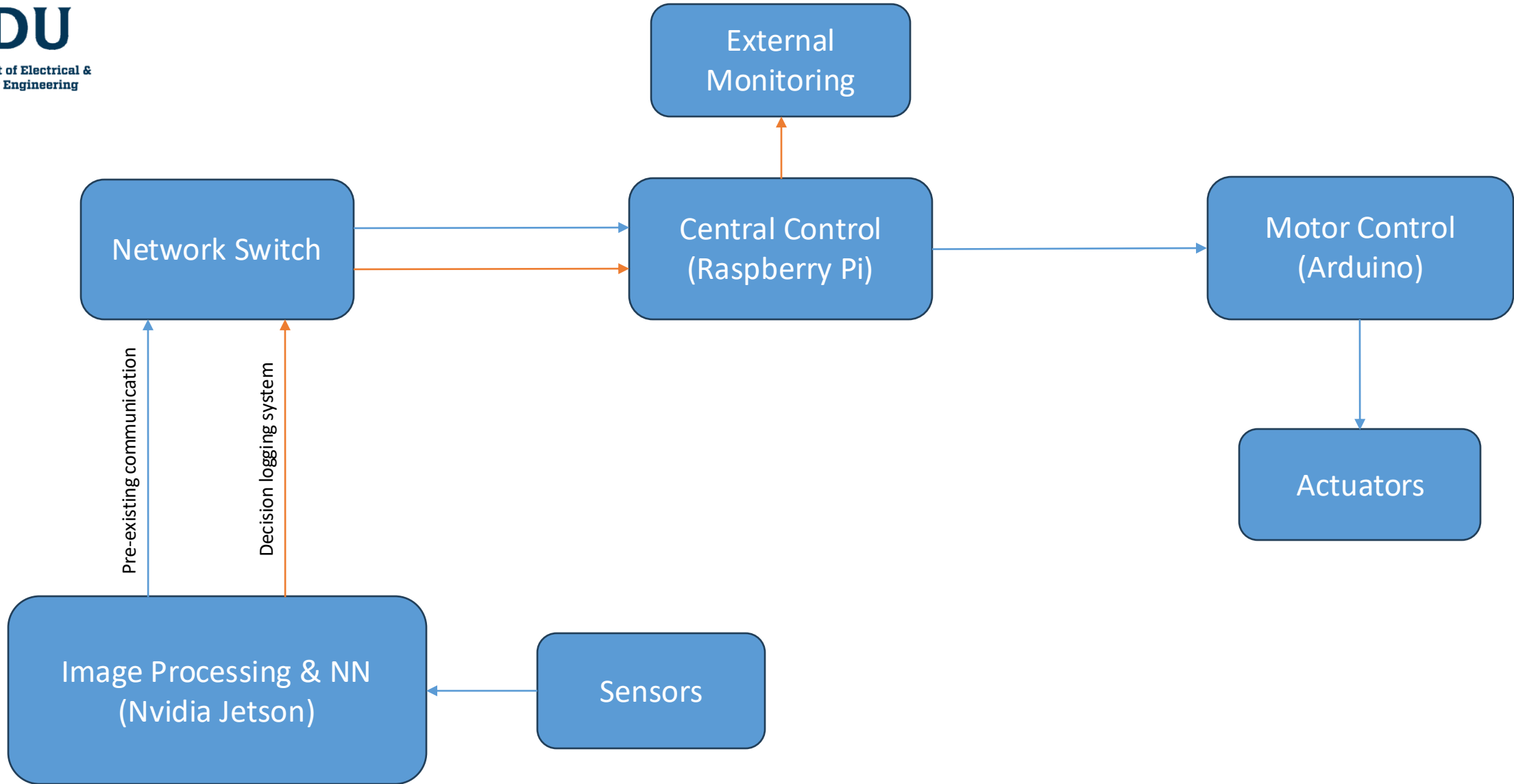

INTELLIGENT GROUND VEHICLE OLD DOMINION UNIVERSITY

Design an autonomous ground vehicle capable of navigating the Intelligent Ground Vehicle Competition course.

Team Members: *Patrick Rogers, Makarios Sugarman
(online group)*

Advisor: *Dr. Lee Belfore*

Design Challenge

Build on the current system to improve capability and competition performance.

Design Goals

- Create a method to save field input data.
- Create a method to save field actions.
- Create a method to streamline training process

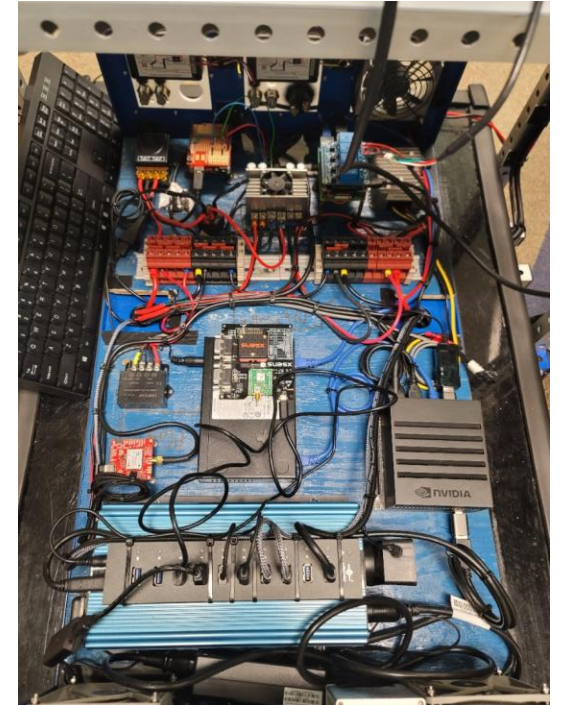

Vehicle internals [1]

Learning happens during the process, not at the destination.

[1] Clark, D., Ellenwood, J., Michalick, J., & Belfore II, L. A.. (2026). *Light weight neural network for lane following and obstacle avoidance* [Manuscript submitted for publication].

AI-Powered Intelligent Tutoring System Block Diagram

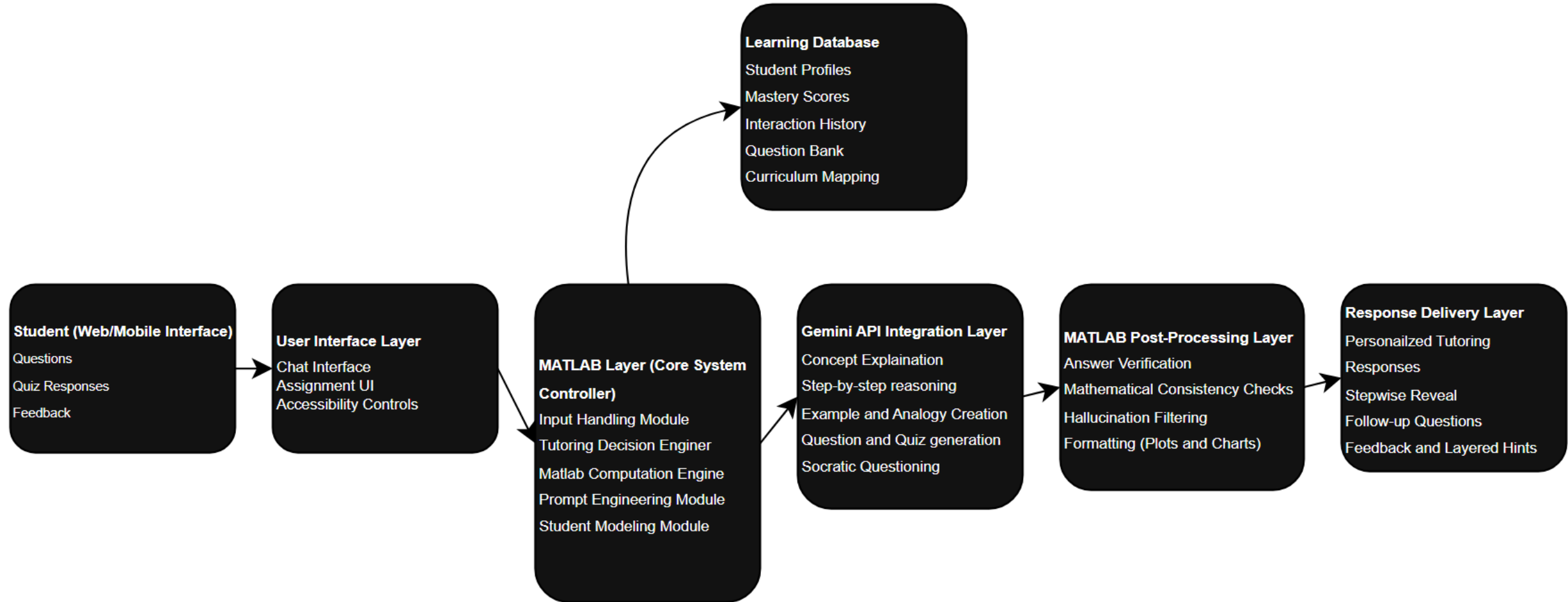

AI-Powered Intelligent Tutoring System

Old Dominion University

This project will see the development of an AI-powered Intelligent Tutoring System using MATLAB APP Designer, Gemini machine learning, and interactive physics-based simulations to support engineering education. The system will integrate AI APIs for human language dialogue, automated answer evaluation, adaptive questioning, and real time feedback to the user.

Team Members: Demetrius Rodriguez, Josh Bradshaw, Rayane Chetouani (online group)

Advisor: Gon Namkoong

Design Challenge

Design an AI-powered Intelligent Tutoring System that delivers an adaptive, interactive, and concept-driven learning experience for engineering students.

Design Goals

- Integrate MATLAB App Designer with interactive physics simulations
- *Provide an intuitive, student friendly user interface*
- Adapt question difficulty based on student performance on previous questions



“Artificial intelligence is a tool, not a replacement for human intelligence.” – Fei-Fei Li