



OLD DOMINION
UNIVERSITY

ODU's 4th Annual Maritime Conference

*NextWave: Advancing the Future of Shipbuilding and Ship
Repair through Industry Collaboration, Innovation and
Workforce Development*

March 10, 2026

Elsbeth McMahon, PhD

Associate Vice President for Maritime Initiatives



Thank you to our Sponsors

Breakfast Sponsor:



Thank you to our Sponsors



Luncheon Sponsor:





Thank you to our Sponsors

Luncheon Sponsor:



Thank you to our Sponsors



Luncheon Sponsor:



Thank you to our Sponsors



Reception Sponsor:



RIVERPORT

Thank you to our Partners:



VIRGINIA SHIP REPAIR
ASSOCIATION



HAMPTONROADS
WORKFORCECOUNCIL
ONE REGION. ONE WORKFORCE. ONE ECONOMY.



Old Dominion University



First-rate research, in-demand majors and real-world experience

Location

- Virginia's forward-focused public doctoral research university
- Tied to the regional maritime industrial base (MIB) with strong industry partnership

People

- ~23,000 students (5,000 graduate)
- 165,000+ alumni
- Top rated veteran friendly university with dedicated offices and resources
 - ~25% military affiliated, 12% undergraduates are Active Duty or Veterans

Academics

- 175+ programs
- 120+ online via ODU Global

Impact

- Initiatives that contribute **\$2.6** billion annually to Virginia's economy
- R1 status, ranking among the top 4% of national institutions in research productivity



Why Maritime?

70% of the earth is covered by water; ~90% of global goods travel by ship

Virginia's Coastal Zone

- 5,000 miles of shoreline and four tidal rivers
- One of the world's deepest natural harbors currently being deepened and widened

Industry Impact

- Largest concentration of shipbuilding/repair/trade activity in the country
- Top east coast port and logistics node
- Cluster of related industries in cybersecurity, data, IT, autonomous systems, and alternative energy

Military Presence

- World's largest Naval base and highest concentration of Navy vessels
- National Laboratories: Jefferson Lab and NASA Langley



Maritime Initiatives



Mission

Provide forward-focused education, research, and innovation that promotes the blue economy

Vision

Be a globally recognized maritime center of excellence and a destination for maritime enterprise

MARAD CoE

ODU is a 2024 Maritime Administration (MARAD) designated Center of Excellence (CoE) for Domestic Maritime Workforce Training and Education



Maritime Initiatives

STRATEGIC GOALS

EDUCATION:

Create and expand **interdisciplinary academic programs** and **enrollment** that supports the blue ecosystem

Inspire **leadership** and prepare students for **future success** in not just jobs but in **careers**

ENGAGEMENT:

Grow **strategic partnerships** with industry, government, academia, and community; better connect students and faculty to research, internship, and career opportunities; increase representation at prominent local, national, and international conferences and events

RESEARCH AND INNOVATION:

Accelerate collaborative, interdisciplinary research. Be the **partner of choice** for leading institutions to support the national maritime strategy, solve key **industry problems**, protect the **natural environment**, and contribute to **workforce development** and **entrepreneurial growth**.

Serve as a beacon for innovation and thought leadership

COMMUNICATION:

Increase **marketing, communication,** and **transparency** of internal and external opportunities





Existing Centers and Institutes with Maritime Links

- Center for Coastal Physical Oceanography (CCPO)
- Center for Geospatial Science, Education, and Analytics (GeoSEA)
- Center for Mission Engineering (CME)
- Center for Secure and Intelligent Critical Systems (CSICS)
- Chesapeake Bay Program Coastal Virginia Center for Cybersecurity Innovation (COVA CCI)
- Coastal Engineering Institute
- Commonwealth Center for Recurrent Flooding Resiliency (CCRFR)
- Data Science Institute
- Institute for Autonomous and Connected Systems (IACS)
- Institute for Coastal Adaptation and Resilience (ICAR)
- Maritime Autonomous Systems Test Site (MASTS)
- Maritime, Ports, and Logistics Institute (MAPLI)
- OpenSeas Technology Innovation Hub
- Spatial Analysis Instructional Laboratory (SAIL)
- Sustainable Development Institute (SDI)
- Transportation Research Institute (TRI)
- Unmanned and Autonomous Vehicle Lab
- Virginia Institute for Spaceflight and Autonomy (VISA)
- Virginia Digital Maritime Center (VDMC)
- Virginia Modeling, Analysis & Simulation Center (VMASC)

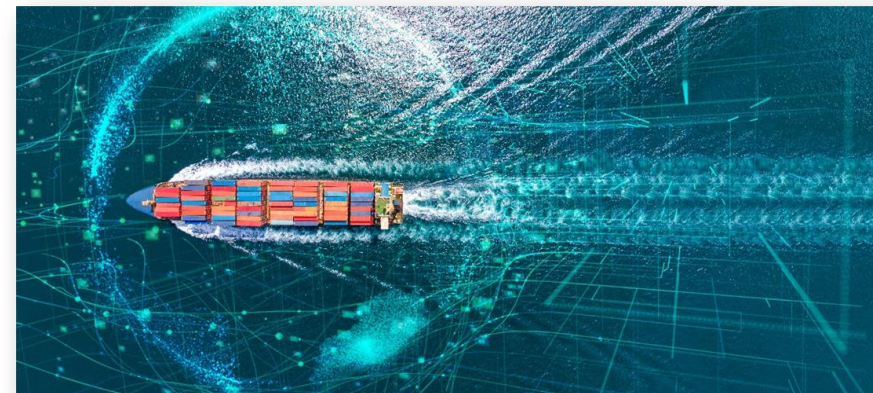

ODU's Maritime Related Degrees and Certificates

Undergraduate

- Biological Oceanography
- Chemical Oceanography
- Environmental Science
- Geographic Information Systems
- Interdisciplinary Studies with a Major in Supply Chain and Maritime Logistics
- Manufacturing Engineering Technology
- Marine Biology
- Marine Science Technology
- Mechanical Engineering Technology
 - Areas of concentration:
 - Marine Systems, Nuclear Systems
- Mechanical Engineering
- Physical Oceanography

Minors

- Environmental Engineering
- Marine Engineering
- Mechanical Engineering Technology
- Maritime and Supply Chain Management

Graduate

- Civil Environmental Engineering
- Environmental Engineering
- Maritime Trade and Supply Chain Management
- Mechanical Engineering
- Ocean Earth Sciences
- Oceanography

Certificates

- Autonomous and Connected Systems
- Coastal Engineering
- Geographic Information Systems
- Marine Engineering
- Maritime History
- Maritime, Ports, and Logistics Management
- Naval Architecture and Marine Engineering
- Spatial Analysis Coastal Environments
- Supply Chain Management

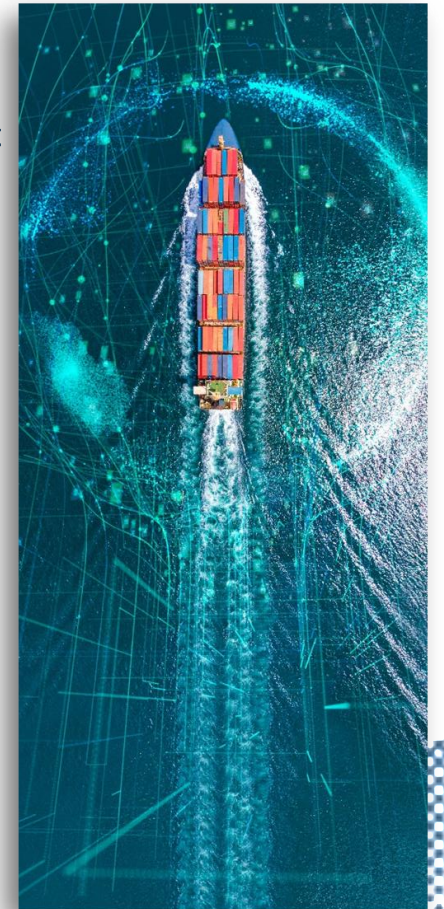



New Courses

- Maritime Leadership, Technology, and Society
- Maritime Security and Risk Analysis
- Maritime Technology
- Cruise Ship Operations

New Hires

Hired 22 faculty members with AI-related expertise as part of our ongoing Centennial Cluster Initiative.

Shipbuilding and Ship Repair Cluster Hires:

- Dr. Katie Smith, Assistant Professor, Engineering Technology
- Dr. Nikolas Xiros, Professor, Engineering Technology
- Dr. Milton Soto- Ferrari, Associate Professor, SSCLMO



Internal Outreach



Maritime Collaborative (M-Collab)

Monarch Internship and Co Op Office (MICO)

Student Clubs

Careers

Mentorship

Networking Events

Industry Visits

Maritime Appreciation Week

Hot topic panels

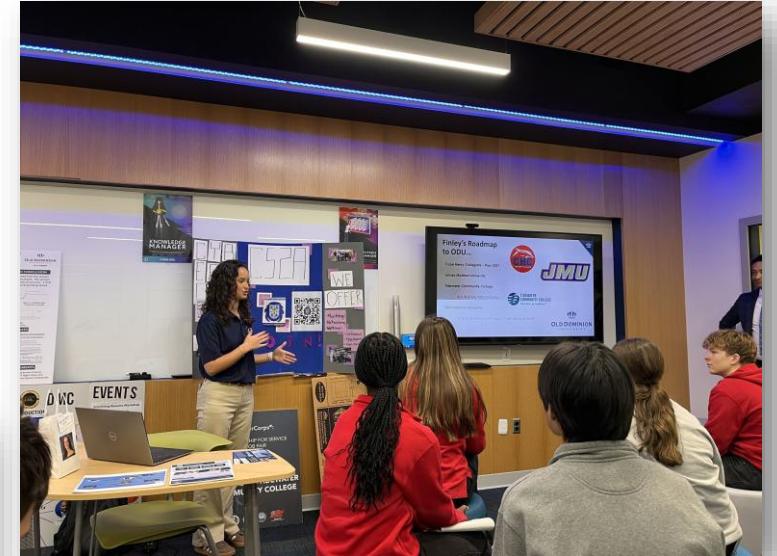



External Outreach

- **Industry, Academic, and Government Partners**
- **Industry Days – HII-NNS**
- **Conferences, Papers, Presentations**
 - IVLP, Natl Academies, VMA, NATO MSRT, SNAME, FMMS, CCALS
 - HRGCC, SOTP, MITAGs
- **Special Courses**
- **K-12 outreach**
 - MEESA
 - VCMC's Digital Ship Challenge
 - Junior Achievement
 - Kidwind
 - Hampton Maritime Academy
 - Maritime Careers events
- **Innovation and Entrepreneurship**
 - small businesses
- **Communication – ODU.EDU/MARITIME**
 - Hot jobs, events



Existing partnerships, associations, & supported events



- American Manufacturing Communities Collaborative (AMCC)
- American Society of Naval Engineers (ASNE)
- Association of Marine Corps Logisticians (AMCL)
- Chesapeake Bay Foundation (CBF)
- Council of College and Military Educators
- Fleet Modernization and Maintenance Symposium (FMMS)
- Friends of US Naval Academy Alumni Association
- Hampton Roads Alliance (HRA)
- Hampton Roads Global Commerce Council (HRGCC)
- Hampton Roads Maritime Industries Education Alliance (HRMIEA)
- Hampton Roads Workforce Council (HRWC)
- I/ITSEC
- Innovate Hampton Roads/757 KidWind
- MARAD's US Center for Maritime Innovation (USCMI)
- Maritime Risk Symposium
- Maritime Securities Roundtable
- NASA
- National Academies' Transportation Research Board, Marine Board
- Navy League
- Newport News Shipbuilding
- NOAA
- Norfolk Naval Shipyard (NNSY)
- OCEANS 22, 23, 24, 25
- Port of Norfolk Propeller Club
- Port of Virginia
- Propeller Club, Port of Norfolk
- Society of Naval Architects and Marine Engineers (SNAME)
- Tidewater Community College
- USCG Evergreen
- US Center for Maritime Innovation (USCMI)
- Virginia Institute of Marine Science (VIMS)
- Virginia Maritime Association (VMA)
- Virginia Ship Repair Association (VSRA)
- Women in Offshore Wind (WOW)
- Women's International Shipping and Trade Association (WISTA)

Division of Research and Economic Development (DivRED)

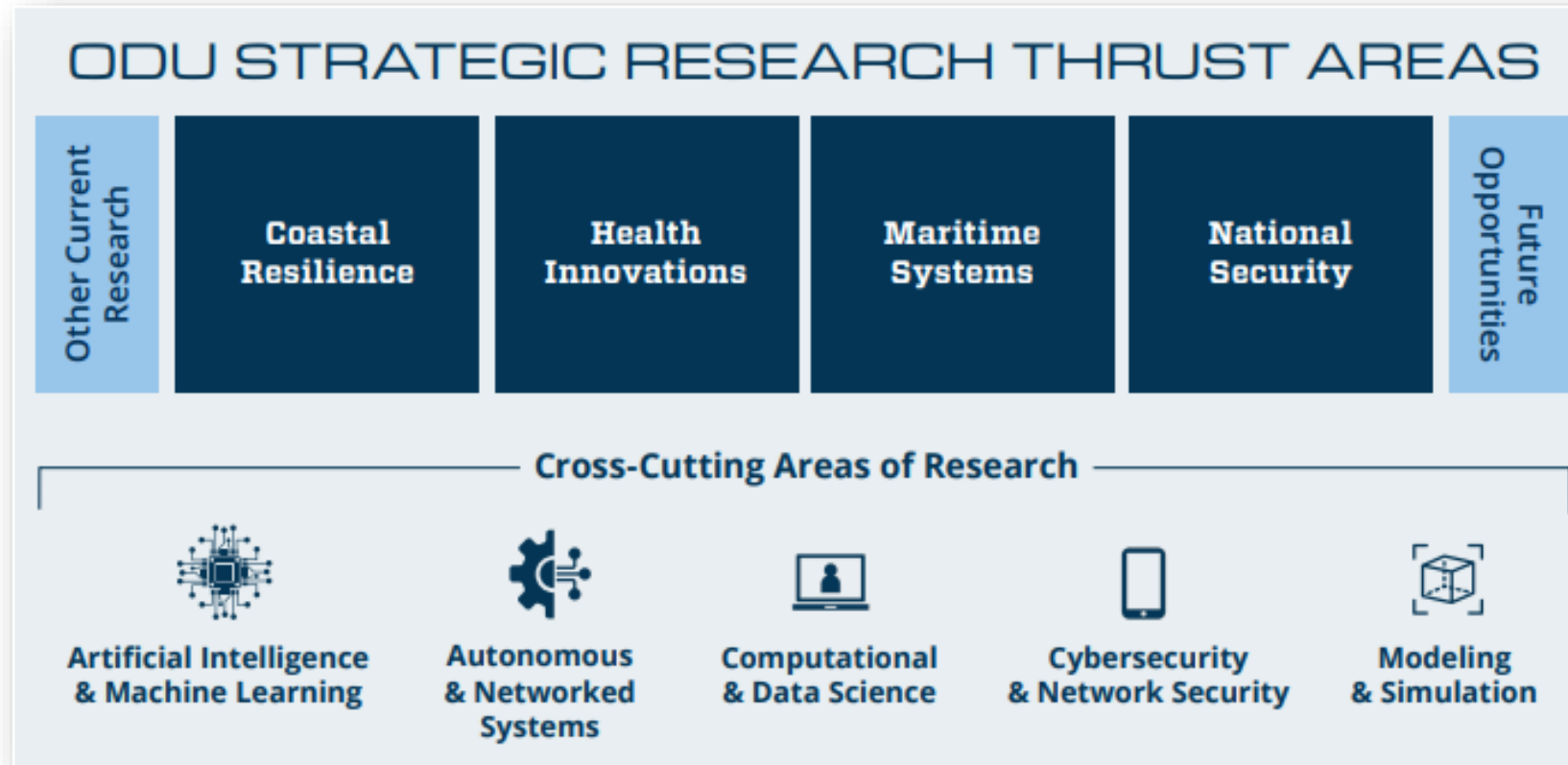

Division of Research and Economic Development (DivRED)



National Security Initiatives



Dr. Marty Irvine, AVP for National Security Initiatives

Previously the executive director of the Naval Surface and Undersea Warfare Centers where he managed more than 30,000 personnel and \$16 billion in research, development, testing and evaluation programs for the Navy

Mission: provide research & technology solutions to our national security problems of today and the future, focusing on:

- *Artificial Intelligence/Machine Learning (AI/ML) & Data Science*
- *Autonomous & Networked Systems*
- *Cybersecurity*
- *Defense Technologies*
- *Modeling & Simulation*
- *Innovate, Educate, Collaborate*

Research – Maritime Systems



Accelerate collaborative, interdisciplinary research and innovation

- Partner of choice to advance **maritime priorities** & strengthen the nation's **maritime enterprise**
- Address **key industry problems** and deliver impactful solutions
- Contribute to maritime related **workforce development** and **entrepreneurial growth**
- Serve as a hub for **innovation**
- Protect the **natural environment**

Maritime Ports and Logistics Institute (MAPLI)

DoL Hampton Roads Workforce
Council (HRWC) Apprenticeship
Grant

Highlight: Maritime Autonomous Systems Test Site (MASTS)



- Willoughby Boat Ramp in Norfolk
- Provide hands-on experience for students and researchers to accelerate the development of maritime autonomy technologies
- Floating dock and ½ ton crane
- 18 chase boat

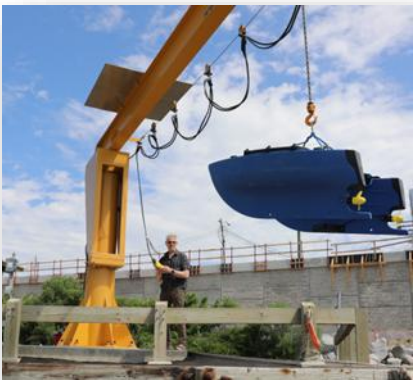



How to get involved:

- **Mentorship**
- **Networking**
- **Internships, Co-Ops, Apprenticeships, Site Visits**
- **Conference, Panels and Campus Events**
- **Guest Lectures**
- **Capstone Projects**
- **K-12 Outreach Events**

Connect: odu.edu/maritime



OLD DOMINION
UNIVERSITY

Research Highlights

ODU Faculty

Kuntal Bhattacharyya

Rafael Diaz

Oleksandr Kravchenko

Nicolas Xiros

Michel Audette

Adel El Shahat

Jessica Johnson



School of Supply Chain, Logistics, and Maritime Operations (SSCLMO) Update

Dr. Kuntal Bhattacharyya, PhD, CRM
Beazley Professor & Director,
School of Supply Chain, Logistics,
and Maritime Operations

Maritime Conference | Tuesday, March 10, 2026





The SSCLMO: at-a-glance

- ❑ Unique dynamics as part of interdisciplinary schools –rooted in industry 4.0 focused curricula
- ❑ Loyalty and support from the local maritime industry (advisory committee)
- ❑ Our Programs
 - ❑ Bachelor of Science in Interdisciplinary Studies with a major in Supply Chain & Maritime Logistics
 - ❑ MS in Maritime Trade & Supply Chain Management
 - ❑ Certificates:
 - ❑ Supply Chain Management
 - ❑ Maritime Ports and Logistics Management
 - ❑ AI in Supply Chains



Shipbuilding & Ship Repair Logistics (SCLM 474/574)



Core Objective: A graduate-level deep dive into the unique constraints of defense and commercial shipbuilding

Strategic Course Focal areas:

- ✓ **Procurement Strategy:** Sourcing for multi-billion-dollar complex defense contracts
- ✓ **Industrial Base Capacity:** Strengthening the network of specialized maritime vendors
- ✓ **Regulatory Compliance:** Navigating Jones Act and federal fleet modernization requirements

Expert Instruction: Led by **Julie Halsey** (Hill Mission Technologies), integrating Australian maritime industry lessons into global supply chain resilience.



School of Supply Chain,
Logistics *and* Maritime
Operations



AI Leadership through Curriculum & Partnerships

- ✓ **Industry 4.0 Core:** Our Supply Chain 4.0 (SCLM 450/550) transitioned from elective to a **required core course** in our MS program and supply chain certificates
- ✓ **Data-Driven Decision Making:** Heavy technical emphasis on ML tools, including:
 - **Python & R Integration:** For predictive maintenance and supply chain modeling
 - **Forecasting Techniques:** Modernizing inventory management for 5,000+ sub-tier suppliers
- ✓ **Splice Partnership:** Real-world dataset access (ocean carriers, port terminals) to automate logistics processes via AI.
- ✓ **Cluster Hire Initiative:** Recent addition of faculty dedicated to **AI in Shipbuilding** as part of ODU's 25-scholar Centennial AI initiative.



Our Core Faculty

Dr. Kuntal Bhattacharyya

Beazley Professor & Director

kbhattac@odu.edu

Dr. Rafael Diaz

Graduate Program Director

rdiaz@odu.edu

Dr. Ricardo Ungo

Undergraduate Program Director

rungo@odu.edu

Sara Russell Riggs, MBA

Senior Lecturer & Alumni Liaison

serussel@odu.edu

Dr. Milton Soto-Ferrari

AI Cluster Fellow

msotofer@odu.edu

Connect with us via  
[linkedin.com/company/odussclmo](https://www.linkedin.com/company/odussclmo)



School of Supply Chain,
Logistics *and* Maritime
Operations

<https://www.odu.edu/supply-chain-logistics-maritime>



Questions? Comments? Discussion...



School *of* Supply Chain,
Logistics *and* Maritime
Operations

Driving Innovation *across* **Supply Chain and Maritime Frontiers**

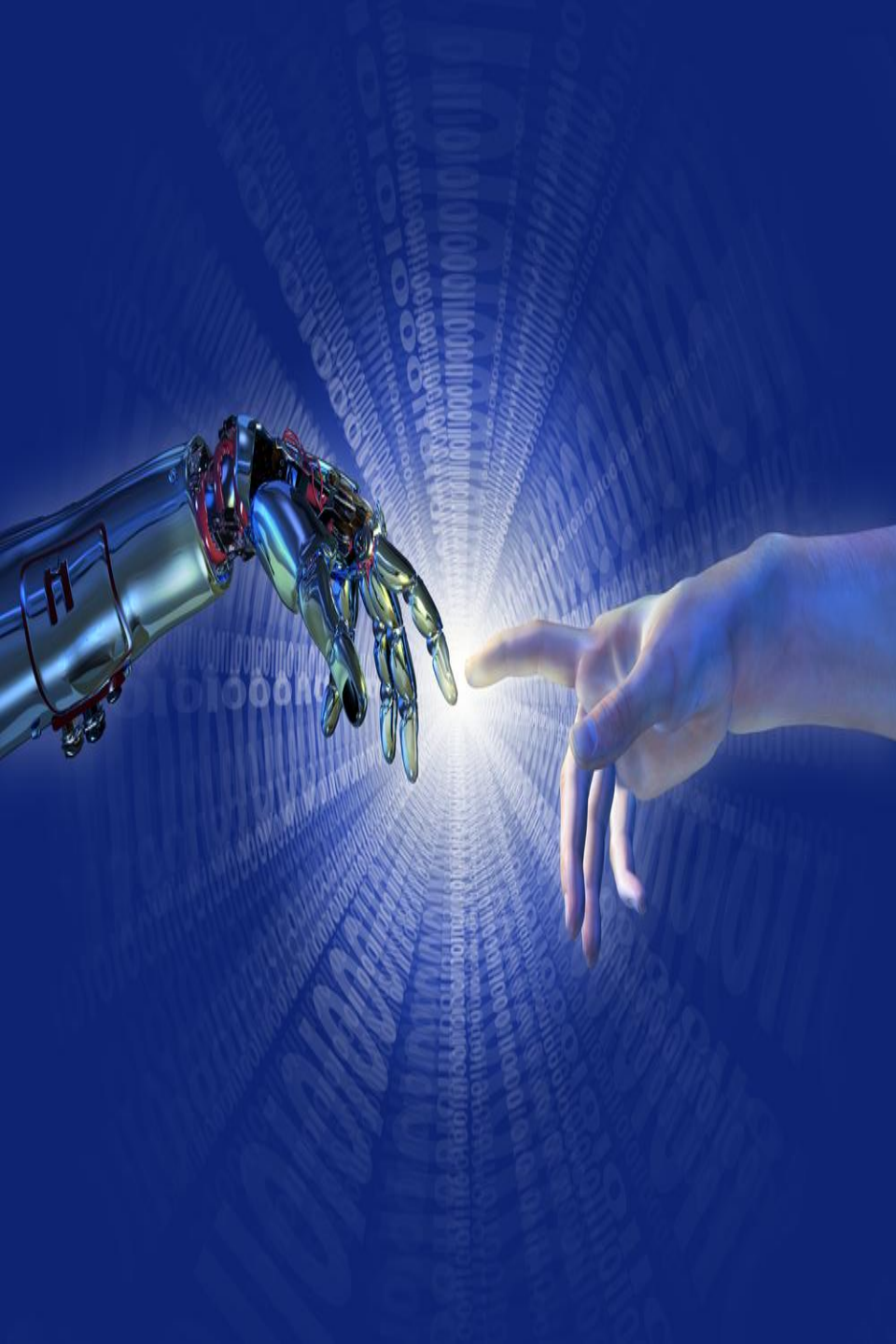

Cybersecurity Supply Chains at a Crossroads: AI in the Age of Disruption

A Maritime Perspective

Rafael Diaz, PhD

Professor, CCI - AI Teaching Fellow
Graduate Program Director
Director of Supply Chain
Cybersecurity Research

Katherine Smith, PhD

Bikash Singh, PhD
Wael Khallouli, PhD
Yezhuo Li, PhD
Joshua Behr, PhD
Zeb Bowden, PhD



School of Supply Chain,
Logistics and Maritime
Operations

Agenda



01 | Background



02 | Projects



03 | Contribution
and Vision

Motivation



**DIB/MIBE
PORT of VA
Collaborators**

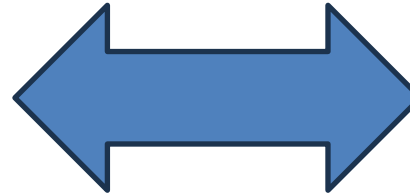

**Research
Question
s**

Manufacturing/Supply Chain Cycle



Upstream activities

Material Convergence/Transformation

Downstream activities

Digitalization / Cybersecurity / OR - OM



Prototype – System information panel



Simulation Planner

Use this panel to review assigned suppliers, run risk simulations, and launch advanced analytics for supply chain decision support.

View Assigned Suppliers

Run Simulation

Monte Carlo Analysis

Supplier Selection Optimization

System Details

Program: Next-Generation Vessel Program

System: NextGen Vessel Platform

Filter Tier: All Suppliers

Tier	Node	Supplier	Country	Lat	Lon
Tier 1 - Component	Hull & Structural	T1 Hull & Structural	US	39.531	-76.362
Tier 1 - Component	Navigation & Sensors	T1 Navigation & Sensors	US	38.079	-75.110
Tier 1 - Component	Propulsion System	T1 Propulsion System	US	38.783	-77.040
Tier 2 - Part	Ballast Pump	Alt Supplier 1 for Ballast Pump	CA	57.148	-68.205
Tier 2 - Part	Ballast Pump	Alt Supplier 2 for Ballast Pump	DE	50.184	8.553

Display details about suppliers over 3-tiers

Upload Data and Analysis

Load Project Data

Scan Supply chain Nodes

Run Simulation

Load case study files

Scan individual nodes

Network-level simulation functions

Selected Suppliers

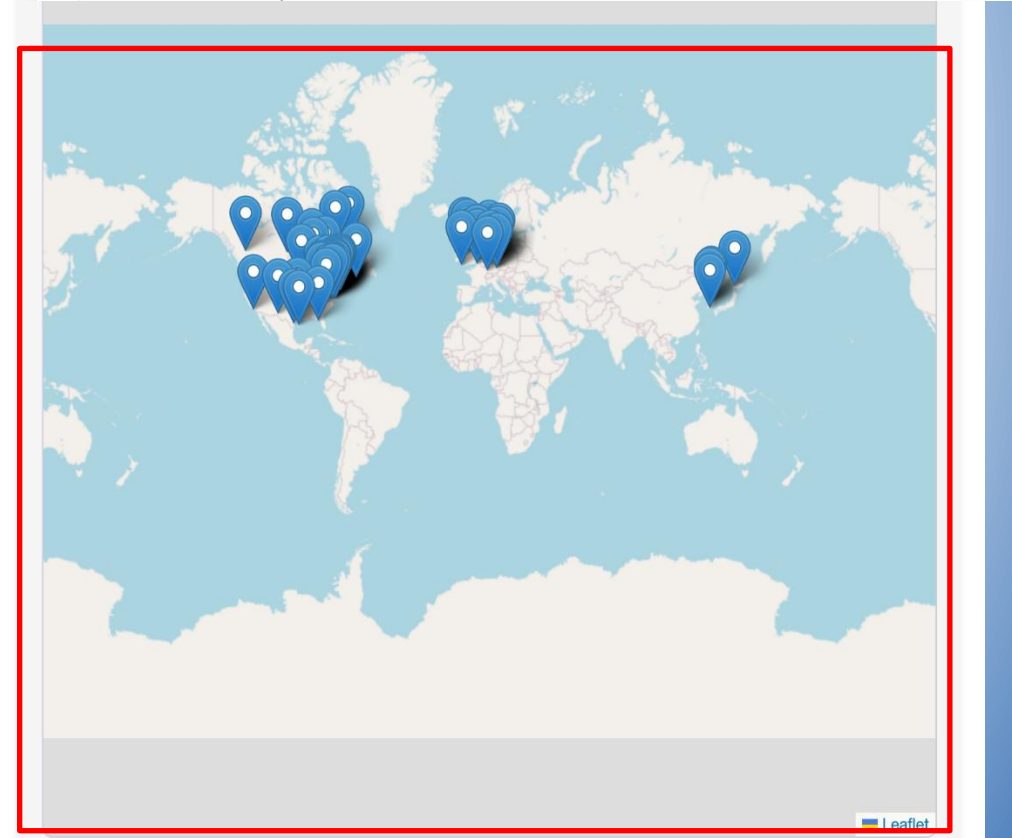
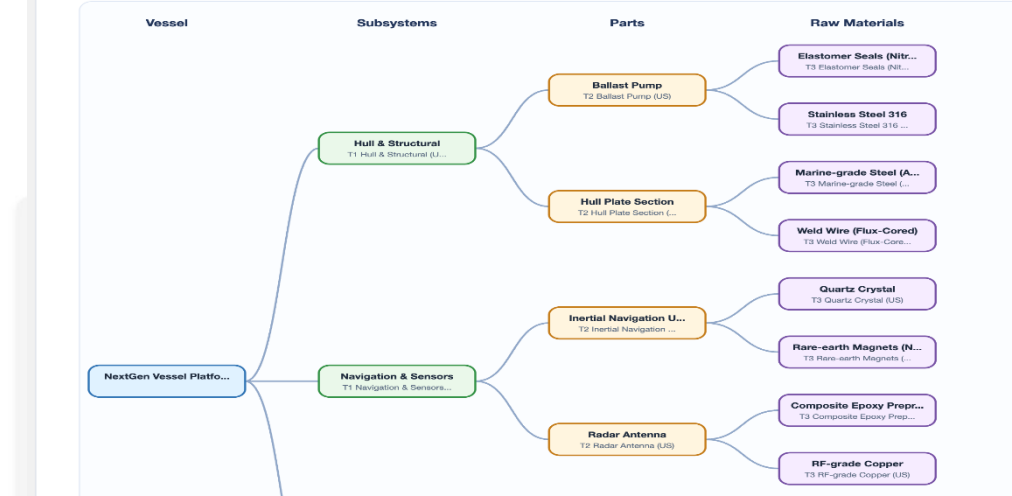

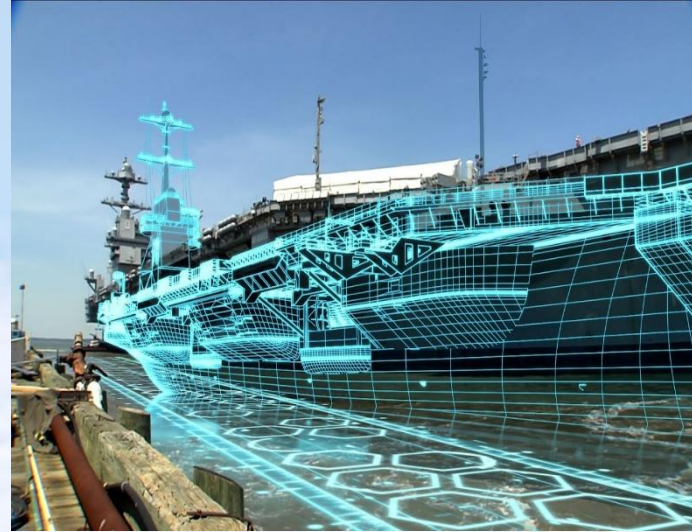

Thank you

**Questions?
rdiaz@odu.edu**

ODU's 4th Annual Maritime Conference

March 10, 2026

Autonomous Watercraft & Marine Robotics

Nikolas Xiros, DEng

nxiros@odu.edu; 757 683 6560

Professor, Engineering Technology

Prof. Mechanical & Aerospace Eng.

OLD DOMINION UNIVERSITY

OVERVIEW OF RESEARCH TOPICS

- Propulsion testing and configuration
- Embedded hardware development
- Surface Effect Ship scale model
- Autonomous homing system using vision feedback
- Prototype design of various robotic vehicle

Electric Propulsion Powerplant Scale Testbed

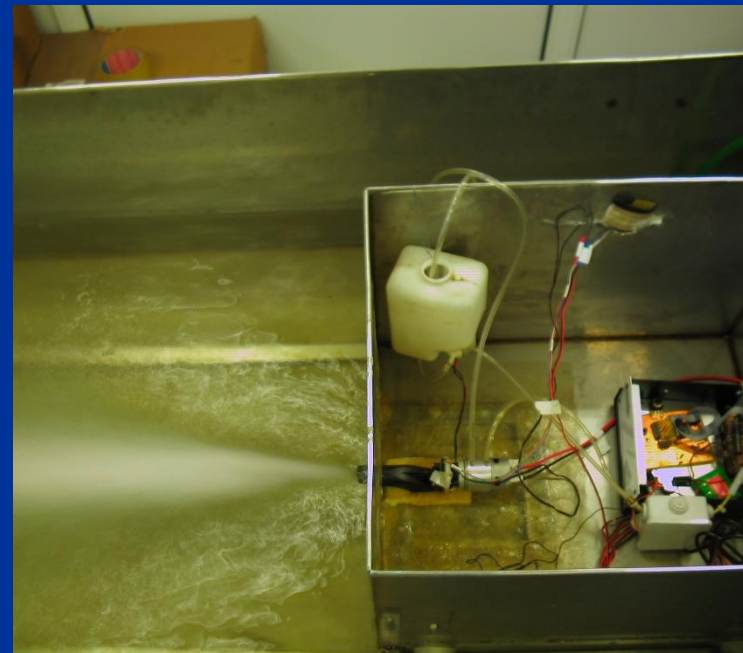
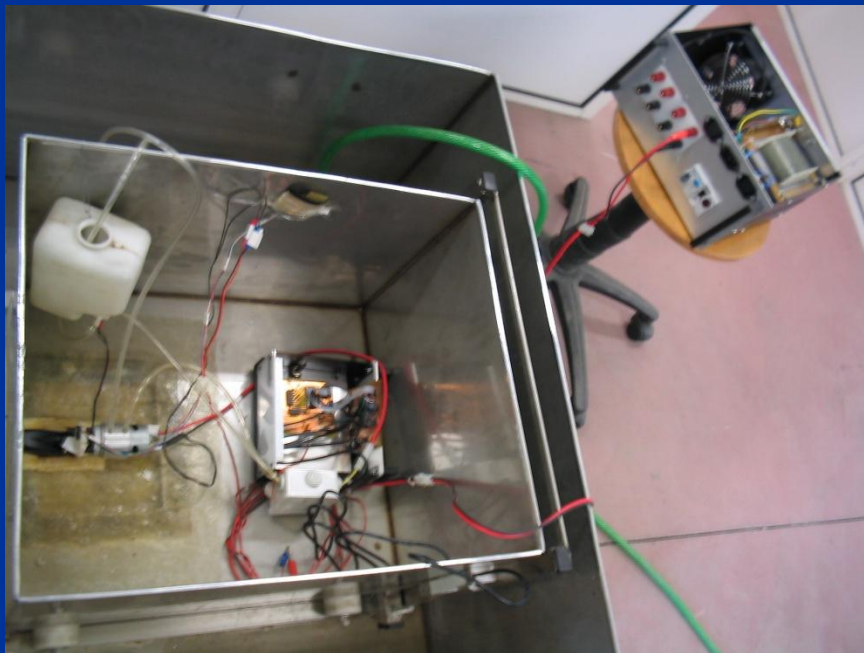
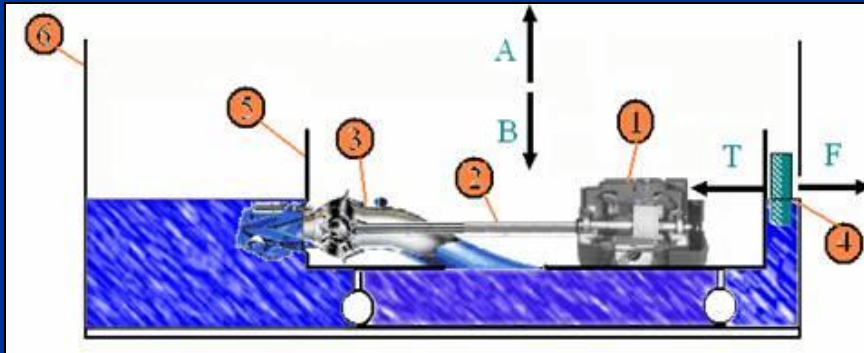

The electric propulsion system testbed:
Principle of operation (top left), powertrain with speed sensor (top right)
and pictures (bottom).

Electric Propulsion Powerplant Testing: Control Hardware

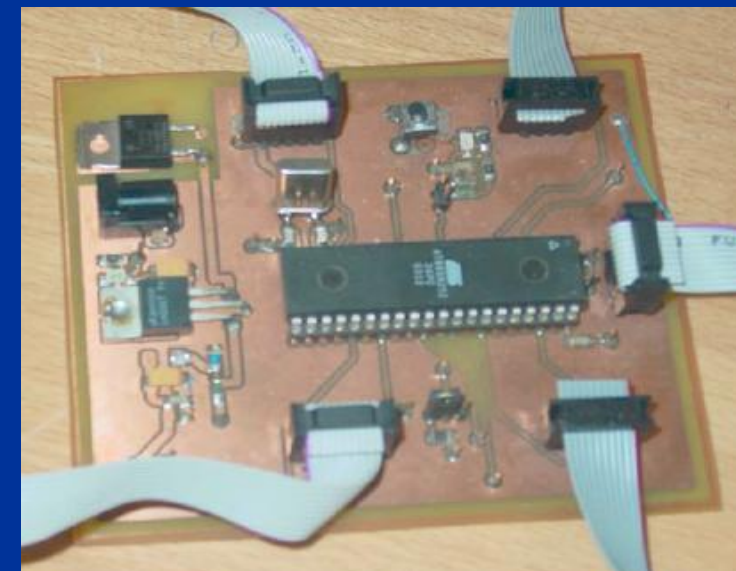
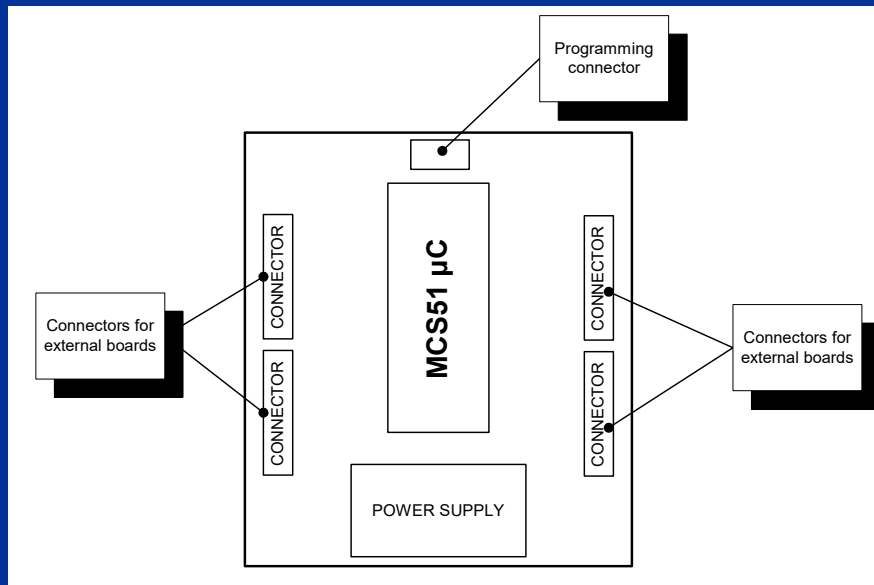
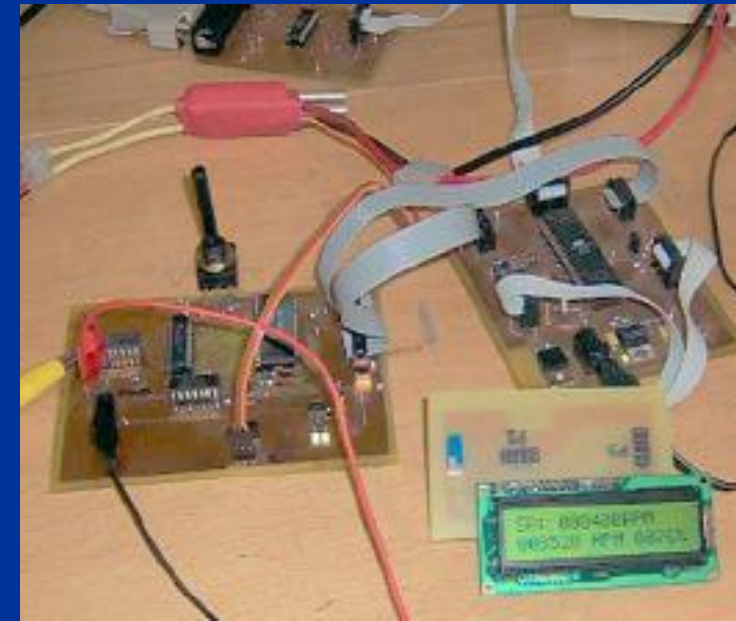
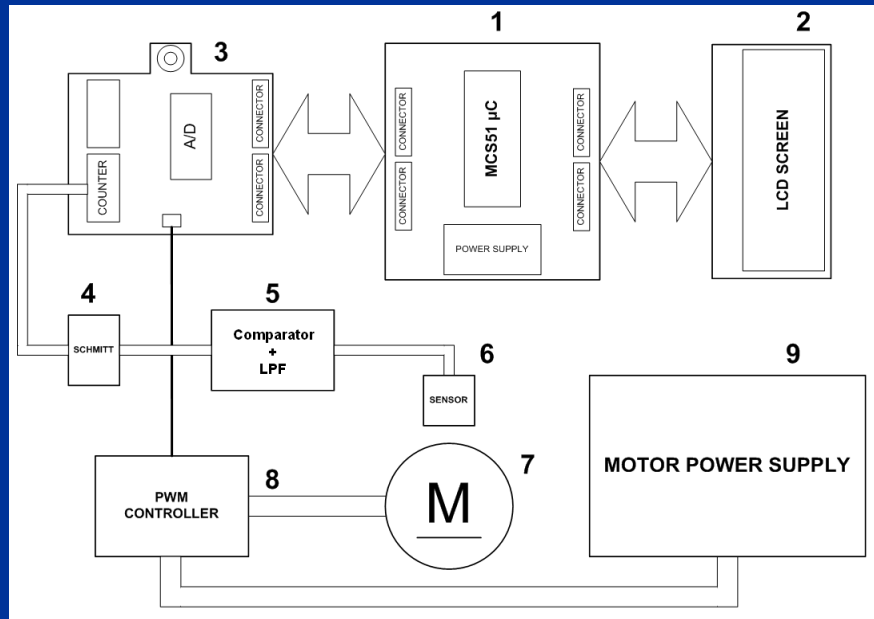

Onboard control computer for autonomous craft

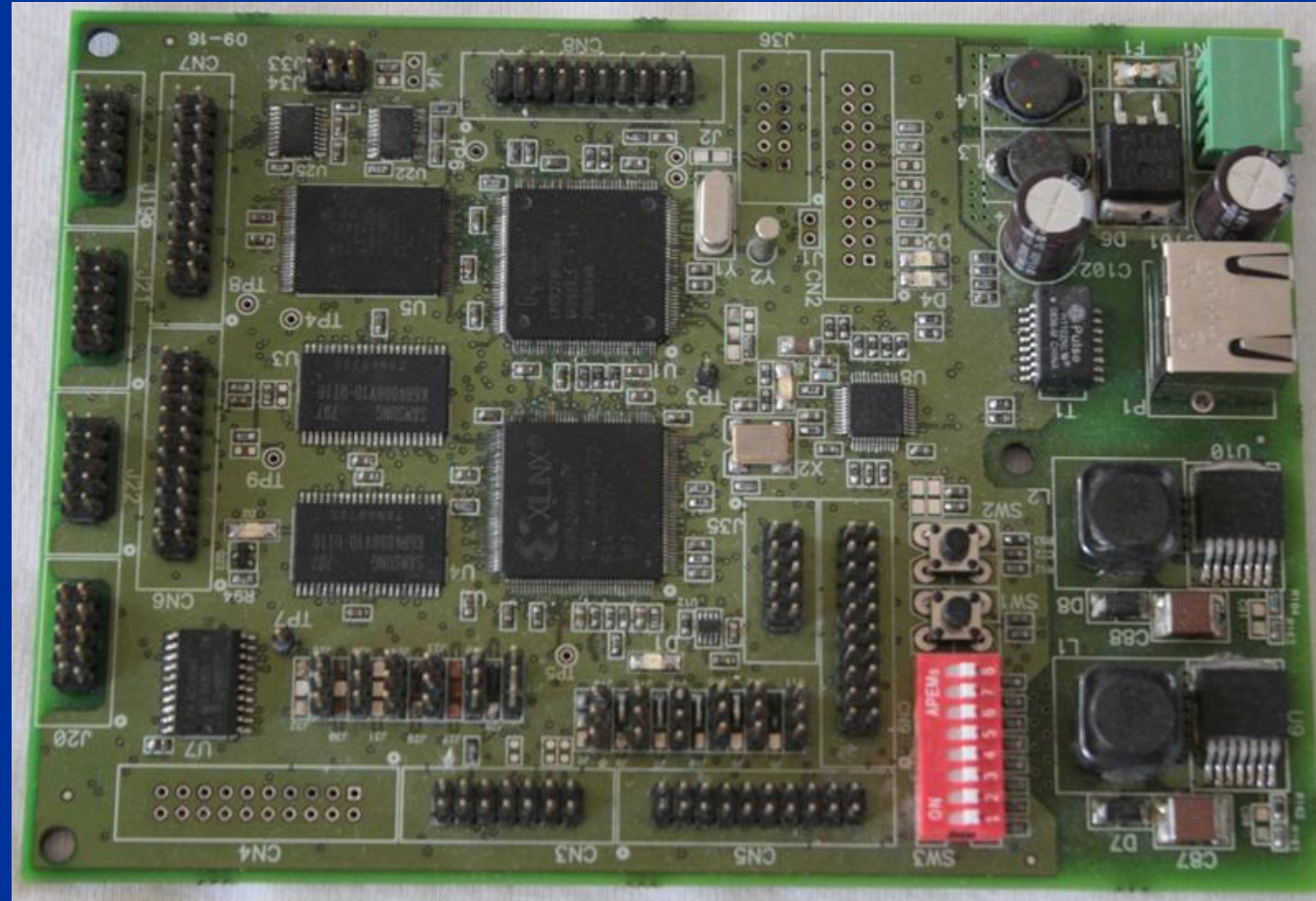

SES model



Trimaran scale model: Towing tank trials

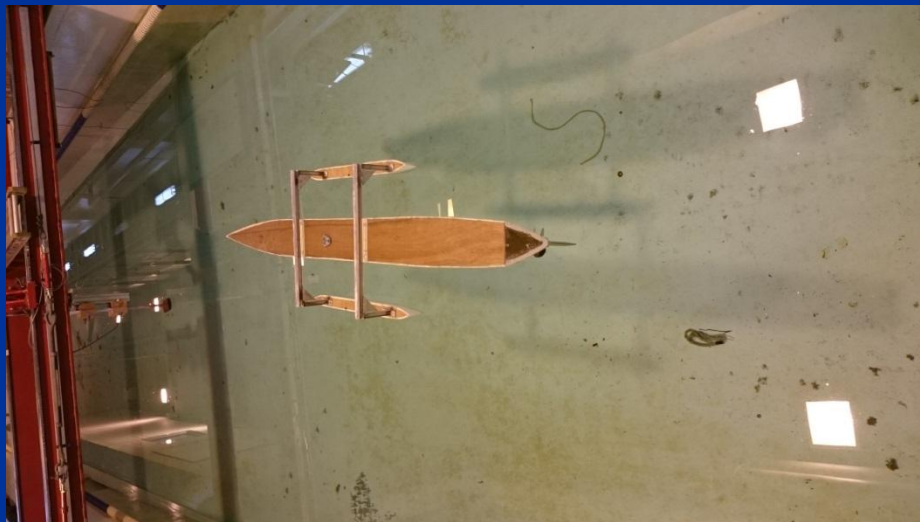
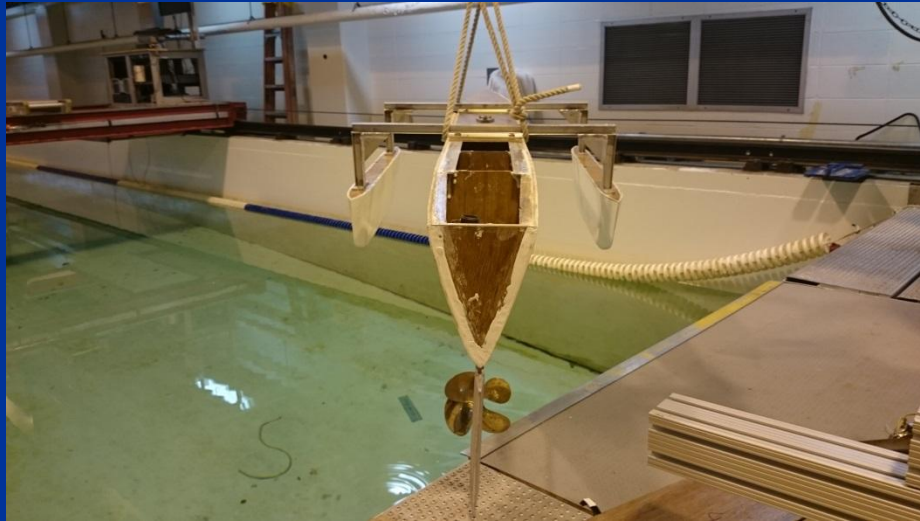

Development of prototype ocean vehicles and watercraft



WAM-V



DUKW

AUTONOMOUS SAILBOAT AND WIND HARVESTING

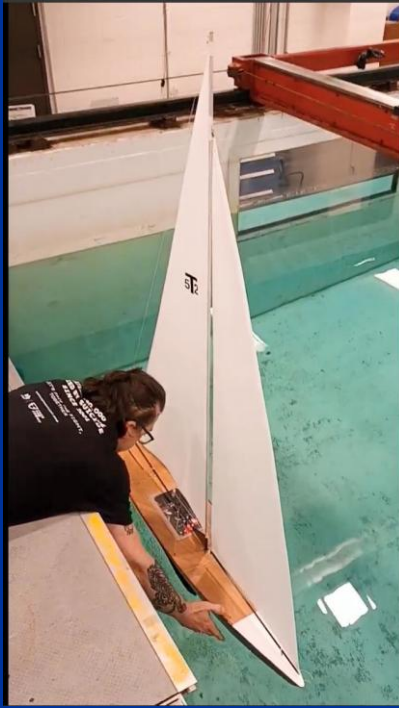

Triangular Platform Dynamic Positioning

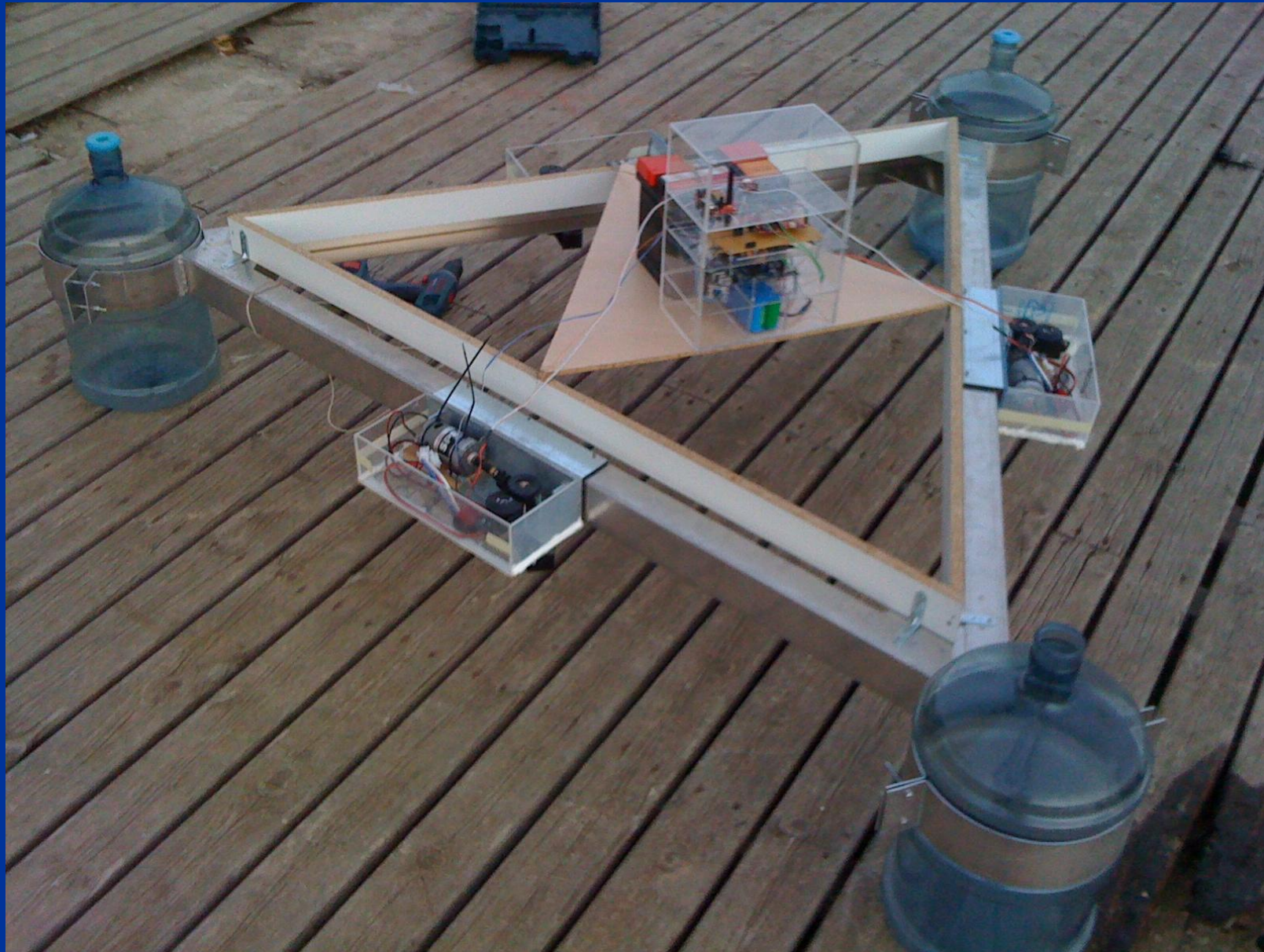

Opportunities in Shipbuilding through Deep Learning, Simulation, and Wearable Electronics and Materials, with Applications to Garment Design

**Michel Audette, Ph.D., Electrical & Computer Eng., Biomedical Eng.,
Hunter Bennett, Ph.D., Human Movement Science,
Mia Joe, Ph.D., Virginia Modeling, Analysis, and Simulation Center,
Old Dominion University**

**MyungHee Sohn, Ph.D., Fashion Design
California State University Long Beach**

**Christopher Paolini, Ph.D., Electrical & Computer Eng.,
San Diego State University**

**Emiel DenHartog, Ph.D.,
Textile Engineering, Chemistry and Science,
North Carolina State University**

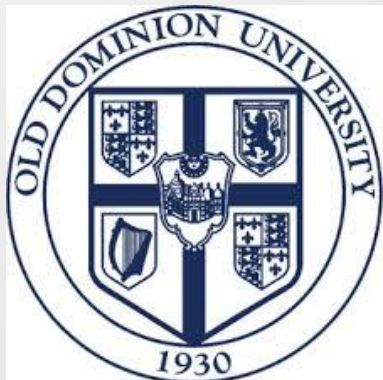

Justification for This Project

Current Challenge

- **Women in shipyard** environments need **properly fitting protective clothing (PPE)** for safety, productivity, and retention.
- **Existing gear** is often designed around **male body shapes** and scaled down, leading to **poor fit, discomfort, or hazards**.
- Designing and manufacturing PPE across the **full range of women's body sizes and shapes** is **seen as complex and expensive**.

Citing Courtney Culpepper*:

The statistics are alarming:

- 🇺🇸 89% of tradeswomen report difficulty obtaining properly fitting PPE .
- ⚠️ 77% have been exposed to safety hazards due to gear designed for men .
- 😞 20% have suffered injuries because their equipment didn't fit their bodies .
- 🚧 65% say badly fitting PPE hampers their ability to do their jobs effectively .

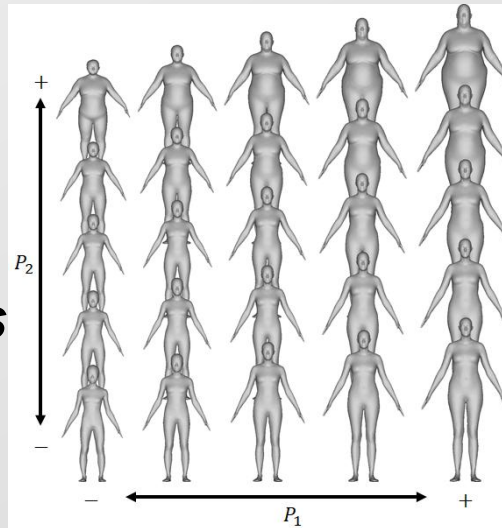

* https://www.linkedin.com/posts/courtneyculpepperconsulting_buildamerica-allhandsondeck-womenintradess-activity-7323397409865097218-RyK6/?utm_source=social_share_send&utm_medium=member_desktop_web&rcm=ACoAAAFZdnQB-CffDkjK8e00XGIUZx7T69RoHso

Justification for This Project – Take 2

- **Related Challenge**
 - Achieving comfort and burn prevention in harsh environments is also challenging.
- **Thermal discomfort and burns** with traditional PPE can occur, while welding.
 - Welder working in sweltering summer heat...
 - ...exacerbated by **radiation hazard**, especially in **confined spaces**.
- **A simulation-optimized digital PPE design process can prevent...**
 - **welding-related burns** through better insulating and fitting garments;
 - **thermal discomfort** through computerized thermal sensing and cooling technologies.



Team Composition

- PI: **Michel Audette, Ph.D.** Computer vision, *medical simulation, human performance, deep neural networks*.
 - Associate Prof., Electrical & Computer Eng., GPD – Biomedical Eng., Old Dominion University.
- CoPIs:
 - **MyungHee Sohn, Ph.D.**, Apparel fit, apparel technology, *apparel design process*.
 - Associate Prof.- Fashion Design, Family & Consumer Sciences, California State University Long Beach.
 - **Hunter Bennett, Ph.D.**, *Musculoskeletal simulations* of activities of daily living and athletic maneuvers.
 - Associate Prof., Human Movement Sciences, Old Dominion University.
 - **Mia Joe, Ph.D.**, Educational technology, instructional design, *shipbuilding industry*.
 - Research Assistant Professor, Virginia Modeling, Analysis, and Simulation Center, Old Dominion University
 - **Christopher Paolini, Ph.D.**, distributed processing & sensing, *smart clothing, embedded cooling*.
 - Assistant Prof., Electrical & Computer Engineering, San Diego State University
- Consultant: **Emiel DenHartog, Ph.D.**, Clothing biophysics, *textile testing, comfort models*.
 - Professor & Department Head Textile Engineering, Chemistry and Science, North Carolina State.

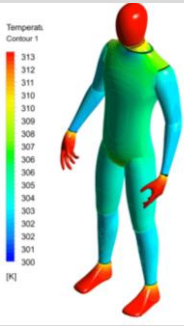
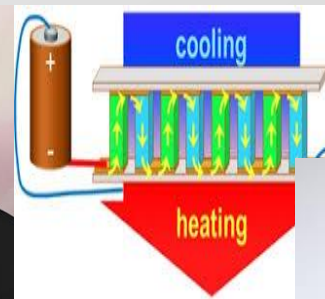

Project 1 – MoCap & Sim-based Welding Clothing

- **Female welders** have **no apparel designed** for a woman's anatomy.
- Combination of **MoCap**, skinned musculoskeletal **welder simulation**, and **real-time simulated clothing** could help **optimize putative apparel designs**.

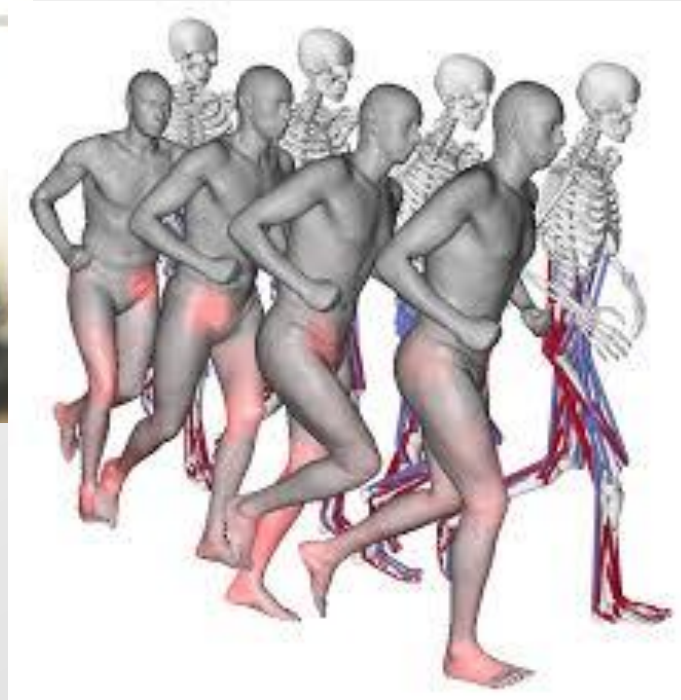

<https://www.mad.tf.fau.de/research/projects/fundamentals-of-biomechanical-simulations/bash/>

<https://medium.com/@designsss/a-beginners-guide-to-creating-3d-fashion-clothing-with-clo3d-386274645b32> <https://github.com/mmmovania/opencloth>

Clothing Simulation- Static 3D + MoCap to OpenSim to Clo3D to FEA Pipeline

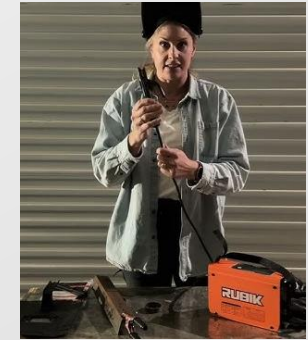
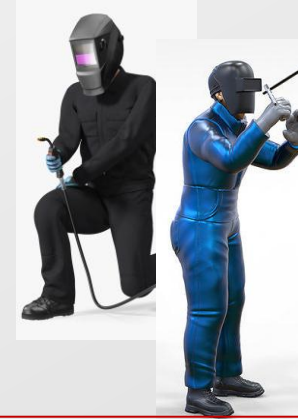
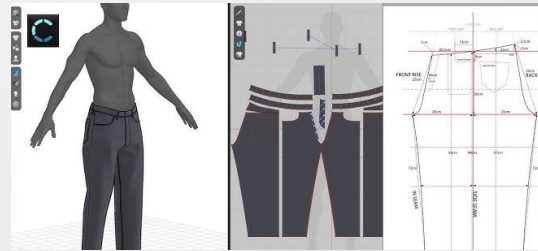
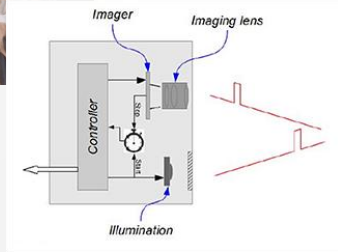

Welder static range captures

Welder MoCaps

Welder shape

Welder pose

Skinned OpenSim MS sim

Welder avatar canonical poses

CLO3D

Garment designs in canonical poses

Welder Feedback

FEA comfort simulation study



Iterate

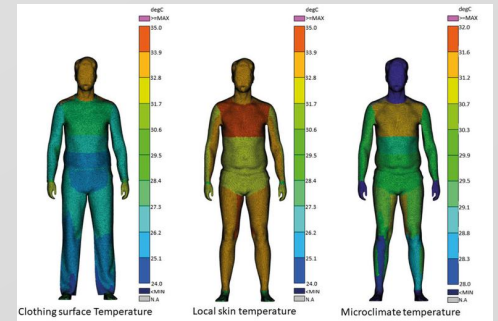

Project 2 –Sim-based Insulative & Thermally Controlled Clothing

- **Insulative & actively cooling** technologies: - **resistance temperature detectors** (RTDs), woven into fabrics;
 - **Aerogel & graphene** insulators; - Textile-embedded **processors**; - Wearable **thermoelectric cooling**.
 - **Embedded physiological sensors** (heart rate, temperature, etc.) also feasible.
- Dr. Sohn can **design garment pattern blocks that accommodate integration of flexible RTDs**, ensuring that seam placement and fabric tension do not interfere with **sensor functionality or wearer comfort**.
- Dr. Paolini is an expert in **distributed sensing & computing**, featuring **wearable PCBs & low-power CPUs**.
- Dr. DenHartog is an expert in finite elements analysis of textiles **for comfort and thermal response**.

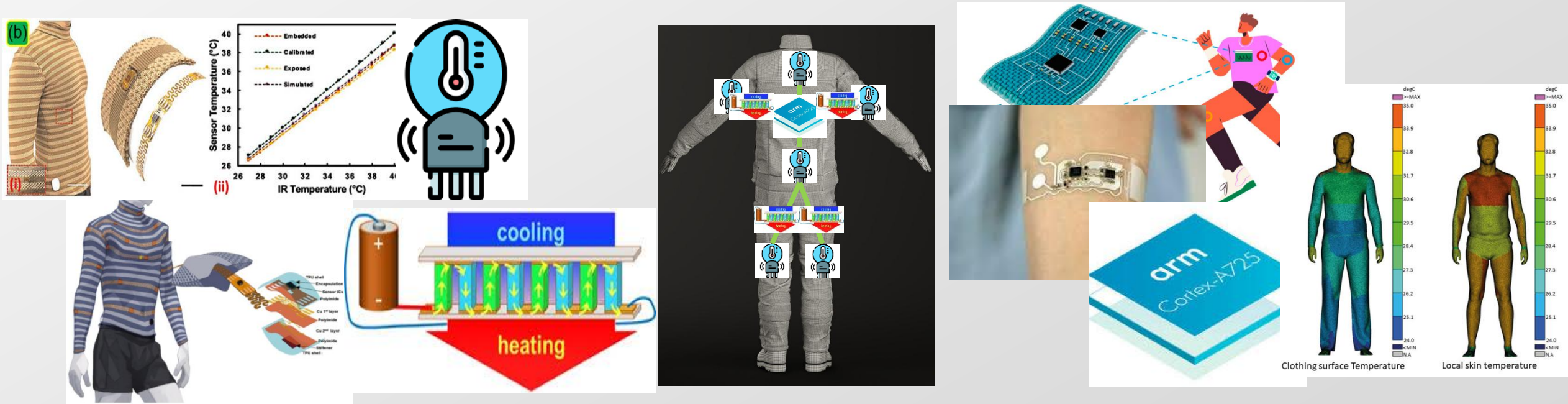

Related Work: Hybrid Simulation- Welding Process & Welder Biomechanics

- ***Basic Idea:*** Use FE synthesis based on DNNs + GPUs for real-time ***welding simulation***, coupled to OpenSim musculoskeletal ***welder simulation***.
- ***Caveats:*** much hinges on ***real-time acceleration of welding sim.***
 - Resolution-controlled mesh, GPUs contribute to efficiencies.
- ***Motion & range capture*** needed of welding processes & typical ship parts.
 - May require clothing design for MoCap of welders.

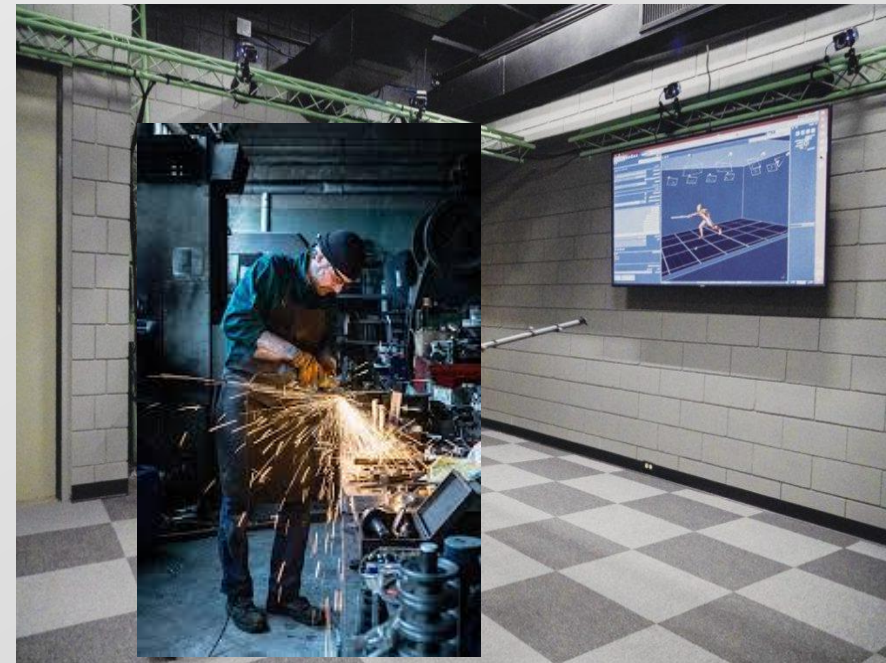

Summary

- Novel development of **simulation pipeline**, featuring **skinned musculoskeletal simulation** based on **motion captures** of welders, pipefitters, painters and other shipbuilders.
- Project 1 centers on **skinned MS simulation & shipbuilder MoCap acquisitions**, applied to **female welder (painter/pipefitter) garment design**. Could improve garments for male shipbuilders.
- Project 2 on **insulative and actively cooling PPE designs**, via woven RTDs, advanced textiles, thermoelectric cooling, and embedded processors, also leveraging **FEA simulation pipeline**.
- Future work feasible in **hybrid welding-welder simulation** & embedded **air cushions** in PPEs.

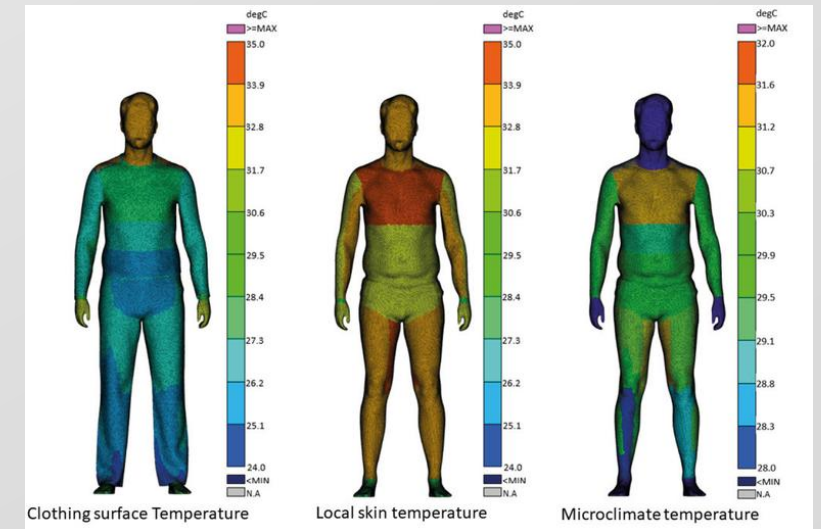



ODU's 4th Annual Maritime Conference

NEXTWAVE 2026



**OLD DOMINION
UNIVERSITY**

**Advancing the Future of Shipbuilding & Ship Repair
Through Electrification, Smart Power Systems, AI,
and Workforce Innovation**

Dr. Adel El-Shahat, PhD, SMIEEE

Department of Engineering Technology

Frank Batten College of Engineering & Technology

Old Dominion University



ADVANCING THE FUTURE OF
**SHIPBUILDING
& SHIP REPAIR**

Agenda

Electrification • Smart Power • AI • Workforce Innovation

***Briefs about:
Past, Present, and Future Research.***



Electrification



Smart Power Systems



Artificial Intelligence



Workforce Development



Maritime Systems at an Inflection Point

Global Drivers

- Naval fleet electrification
- Hybrid & fully electric vessels
- Port decarbonization initiatives
- Industry 4.0 shipyards
- AI-driven maintenance & diagnostics

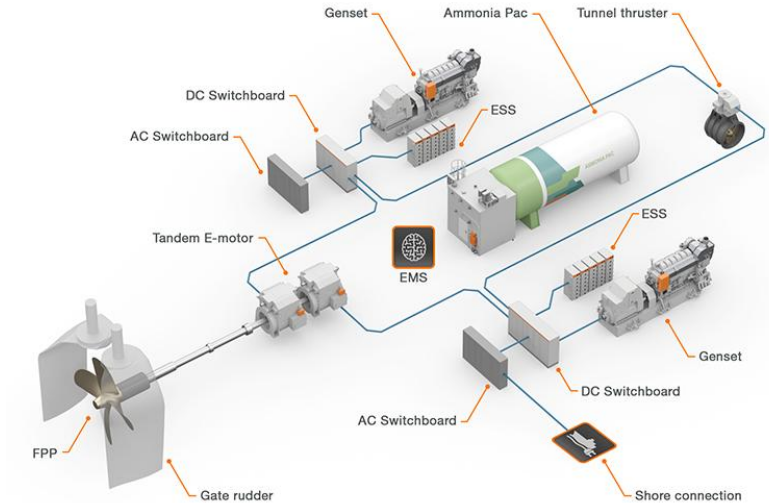
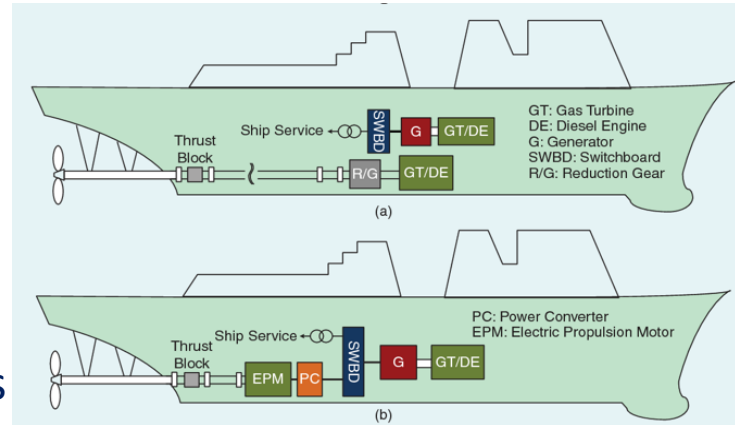

Positioning Statement

Shipbuilding and ship repair are transitioning from **mechanical-dominant systems** to **power-electronics-driven, software-defined platforms**.

My research integrates:

- ⚡ Power systems engineering
- 🔋 Electrification technologies
- 🤖 Artificial intelligence
- 🎓 Workforce innovation

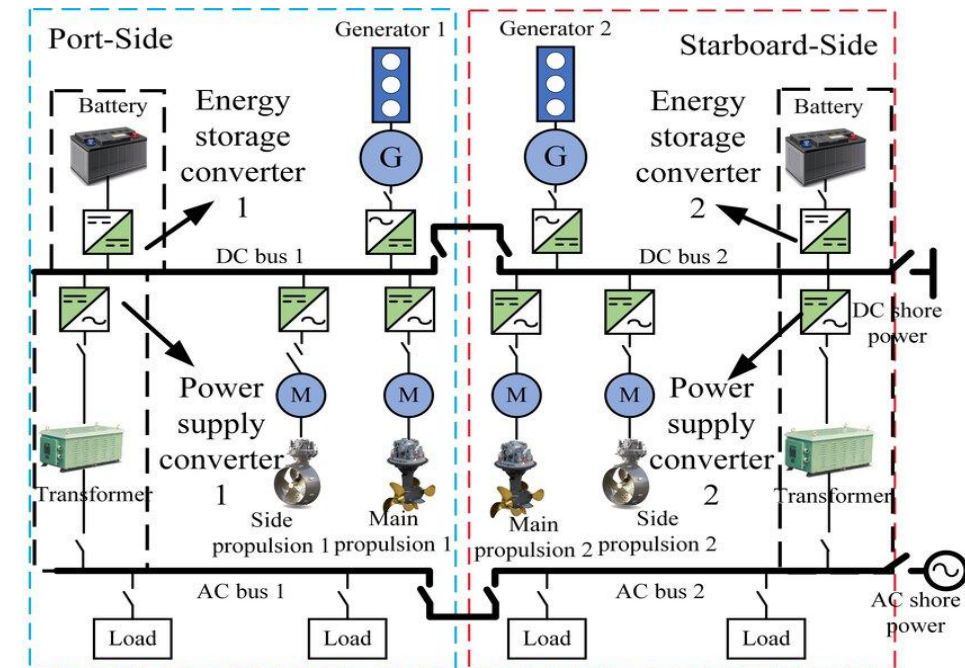

PAST RESEARCH *(Enabling Maritime Applications)*



Electric Machines & High-Speed Generators

Core Contributions

- High-speed PM generator design & optimization
- Induction motor performance enhancement
- Smart-grid generator sizing using metaheuristics
- Advanced electric machine modeling

Maritime Impact

- High power-density propulsion motors
- Auxiliary shipboard generation
- Hybrid diesel-electric retrofits
- Reduced emissions & lifecycle costs

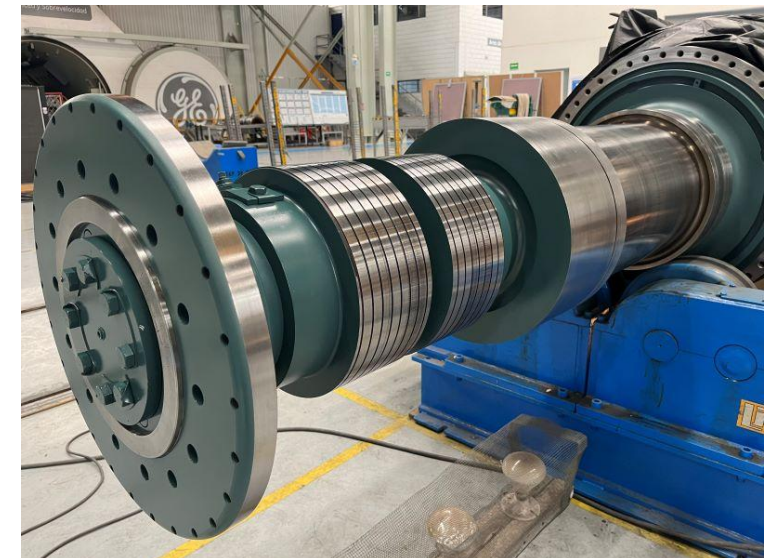
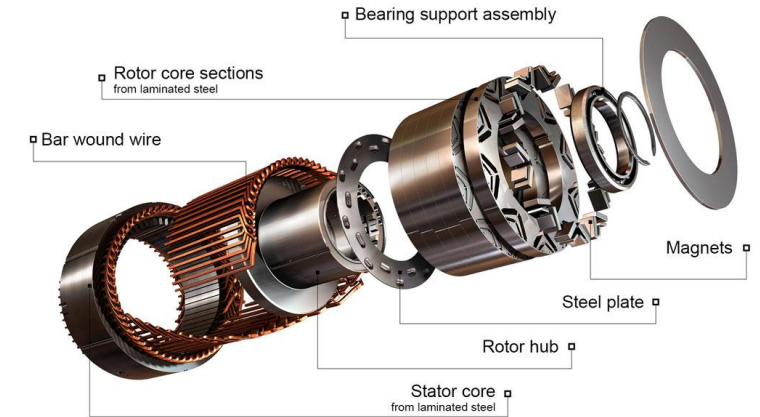

PAST RESEARCH



DC Microgrids & Integrated Ship Power Systems

Research Achievements

- DC microgrid modeling & control
- Grid-forming inverter strategies
- Voltage stability optimization
- Distributed generation integration

Maritime Relevance

- Naval Integrated Power Systems (IPS)
- Shipboard DC distribution
- Shore-to-ship electrification
- Port resilience microgrids

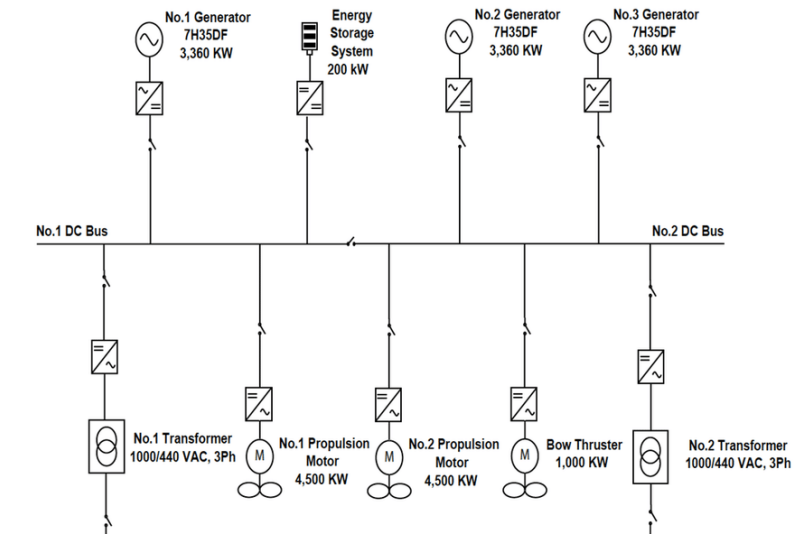
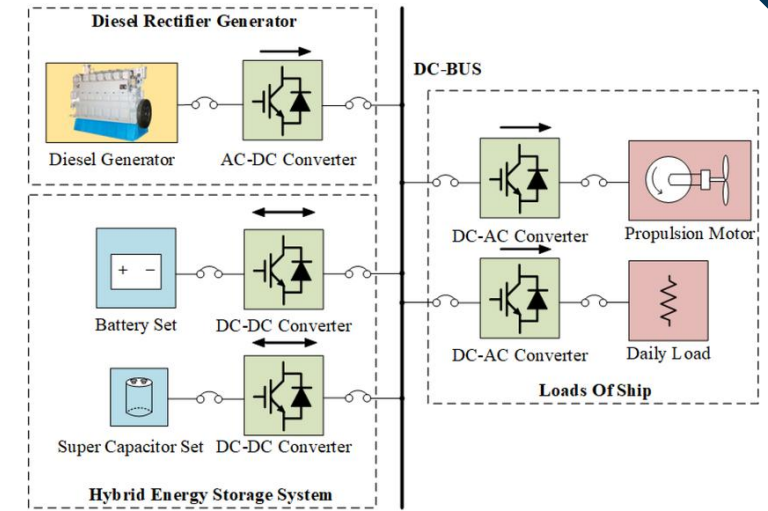
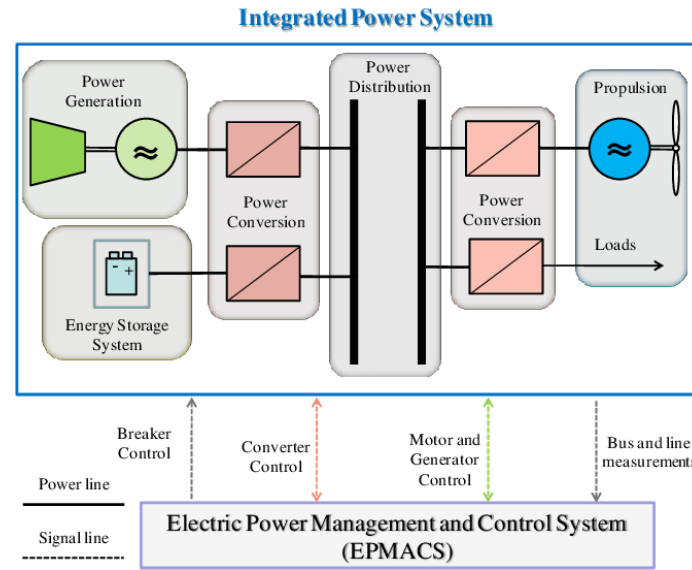

PAST RESEARCH

Wireless Power & Electrified Transportation

Research Focus

- Wireless charging systems
- Human EM exposure analysis
- Smart charging optimization
- AI-based solar prediction

Maritime Extension

- Electric harbor craft
- Autonomous port vehicles
- Shipyard robotics electrification
- Future electric ferry systems

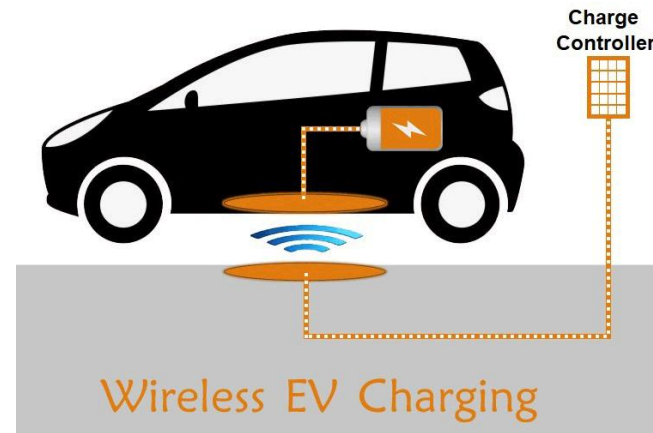



PAST RESEARCH

AI & Optimization for Maritime Power System

Core Expertise

- AI-based anomaly detection
- Deep learning for smart grids
- PSO, GWO, hybrid optimization
- Energy system parameter estimation

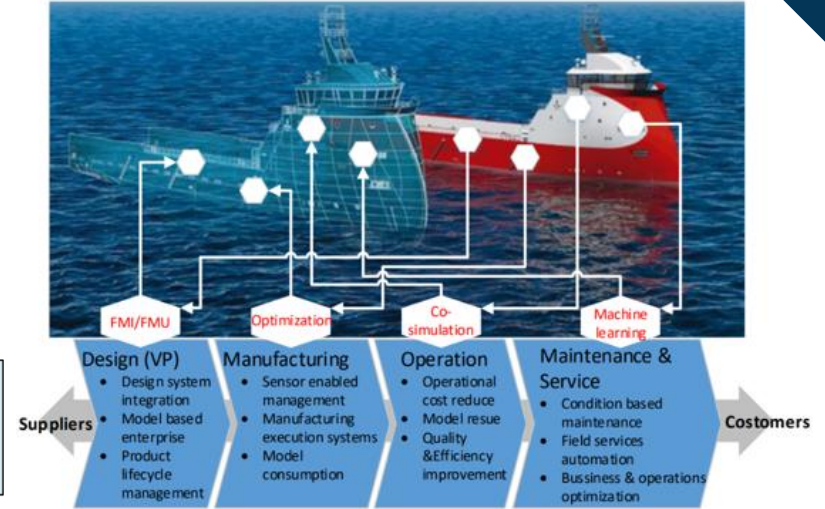
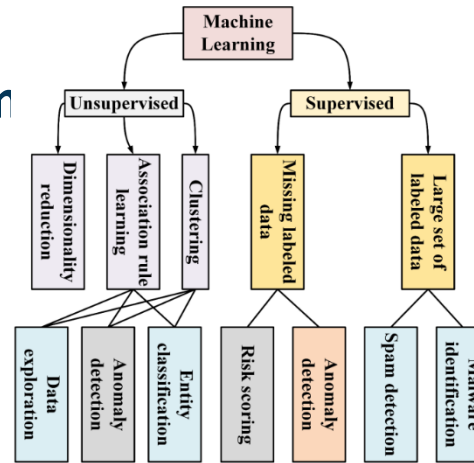

Shipyards & Fleet Applications

- Predictive maintenance
- Ship power fault detection
- Energy dispatch optimization
- Vessel digital twins

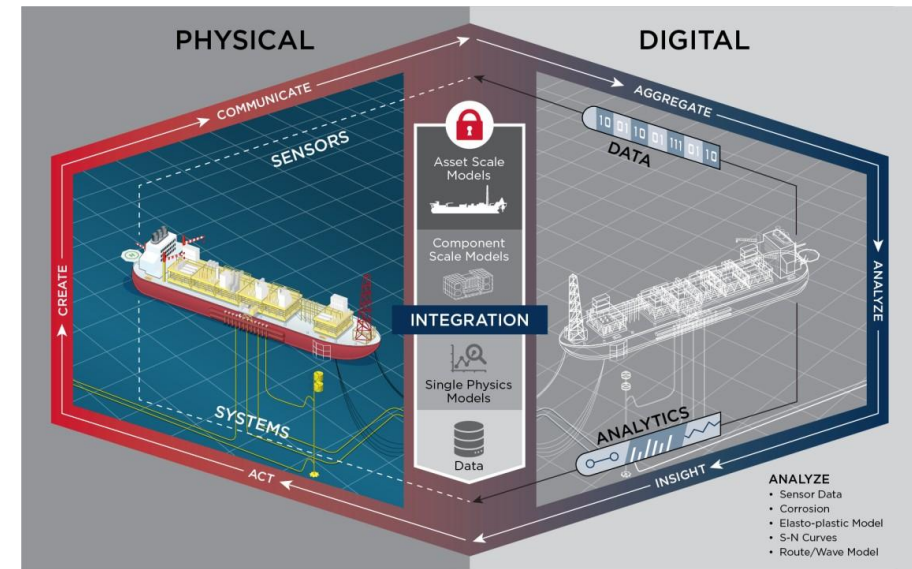
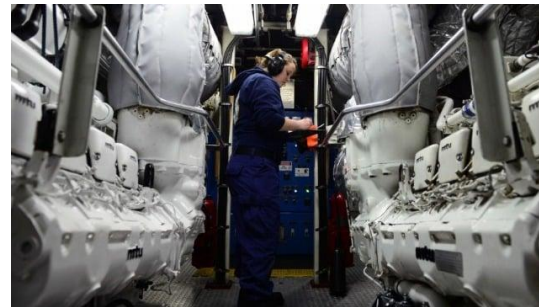



CURRENT RESEARCH *(Maritime-Focused Direction)*

Electrified Ship DC Hybrid Power Systems

Current Work

- GAMS simulation of electrified DC ship systems
- Renewable integration modeling
- Hybrid vessel feasibility studies
- Digital twin-enabled control frameworks

Strategic Impact

- Reduced fuel consumption
- Increased operational flexibility
- Lower lifecycle maintenance costs

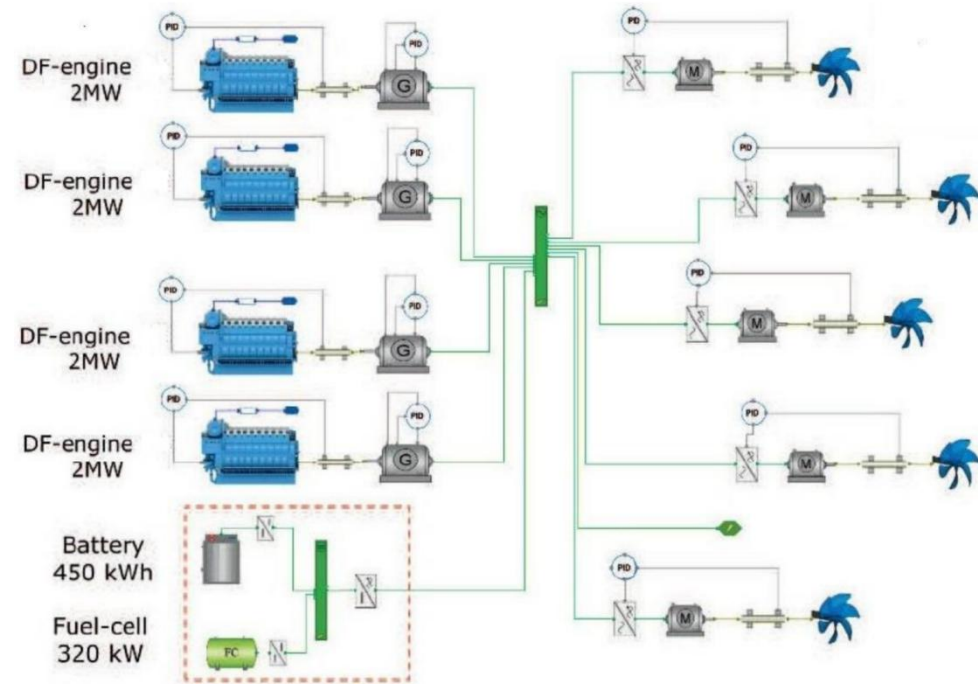
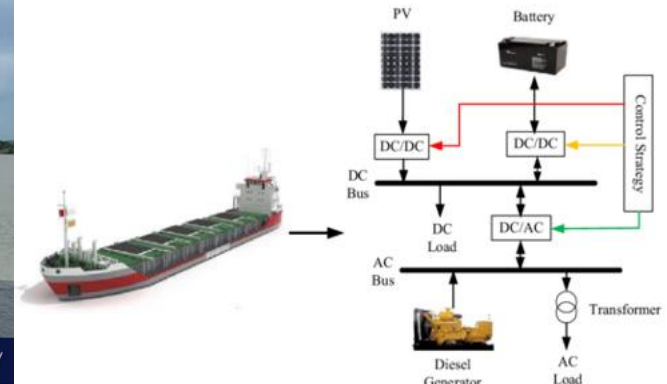

CURRENT RESEARCH

AI-Driven Electrified Material Handling

Shipyards Applications

- Electrified cranes & forklifts
- Intelligent battery management
- Dynamic load energy optimization
- Smart shipyard electrification planning

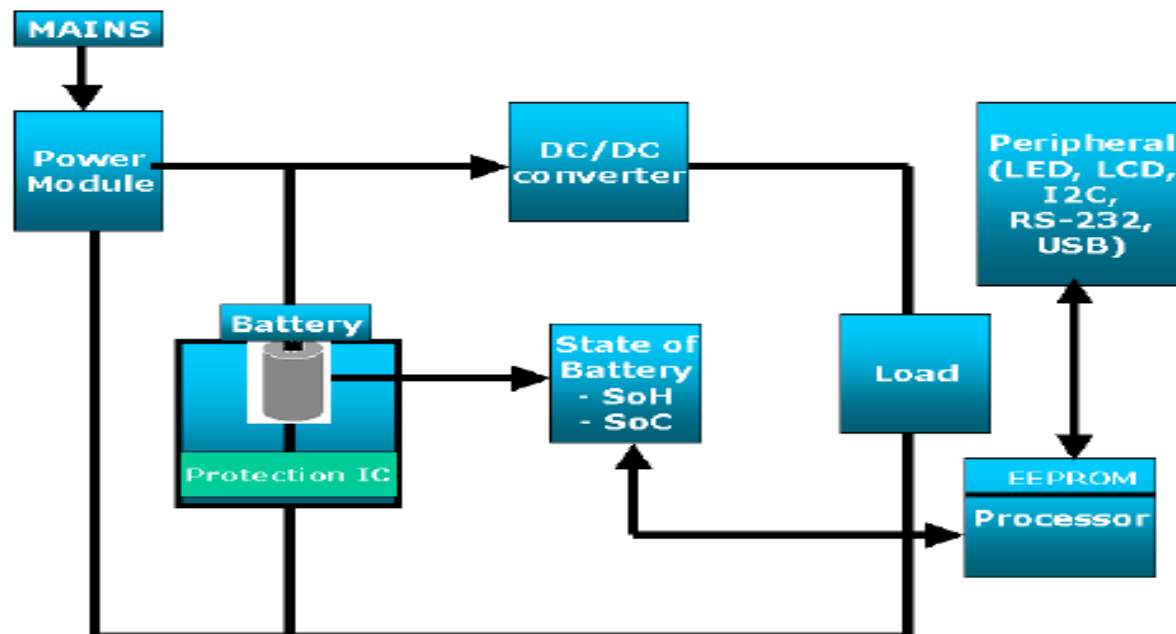



CURRENT RESEARCH

Resilient Maritime Power Under Uncertainty

Maritime Adaptation

- Fault-tolerant propulsion systems
- Latency-aware naval grid control
- Cybersecure shipboard microgrids
- Resilient inverter architectures

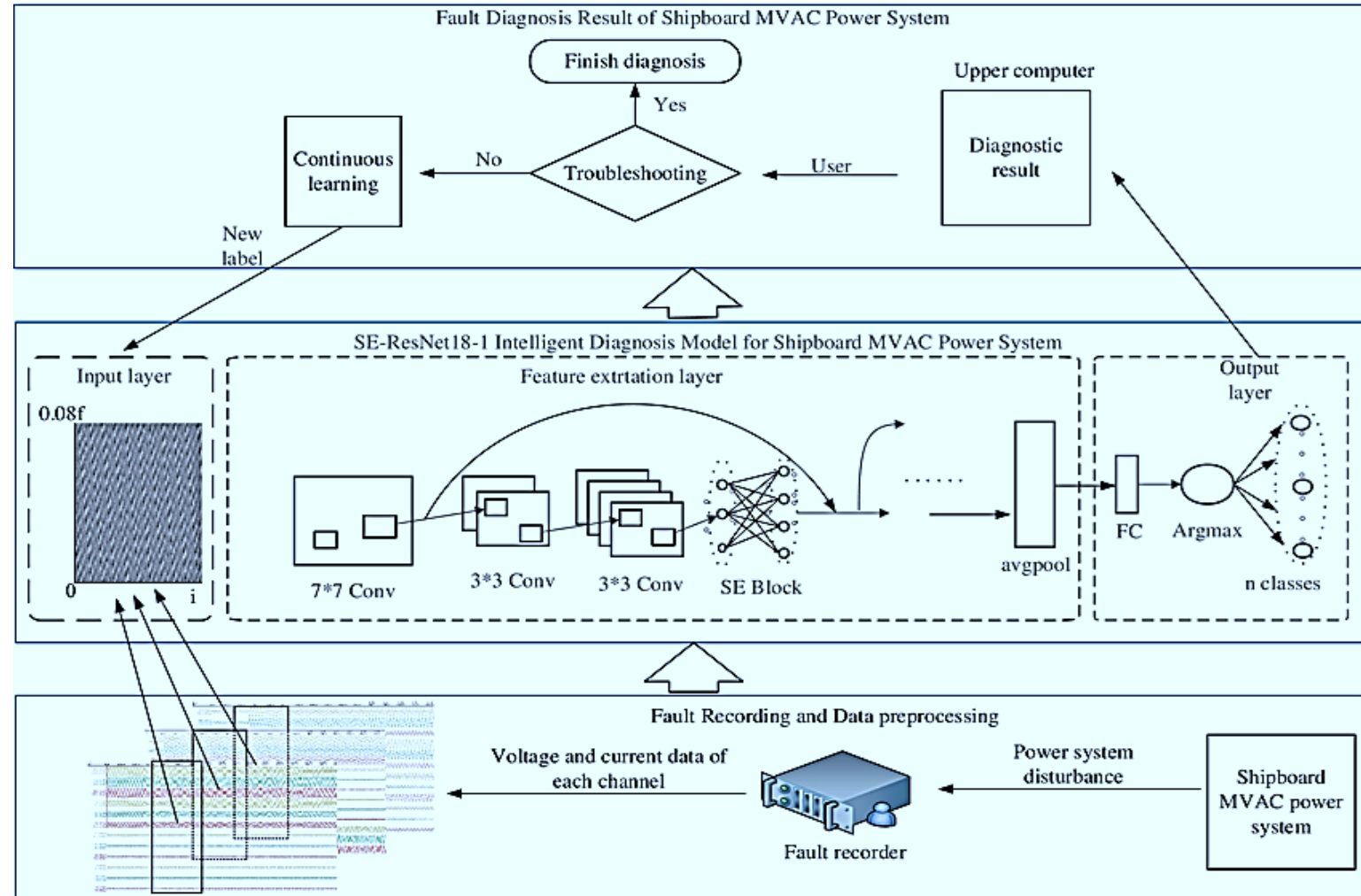
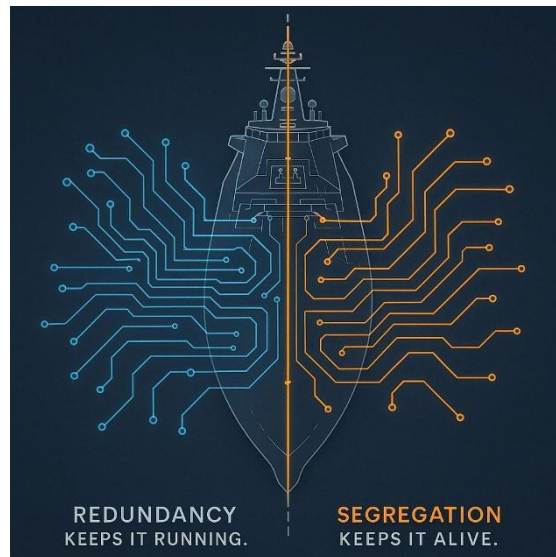



FUTURE VISION

Digital Twin Ships & Smart Shipyards

Planned Research

- Real-time ship power digital twins
- AI predictive maintenance frameworks
- Sensor-driven anomaly detection
- Cybersecure maritime AI systems

AI Predictive Maintenance Across All Critical Ship Equipment & Voyage Impact

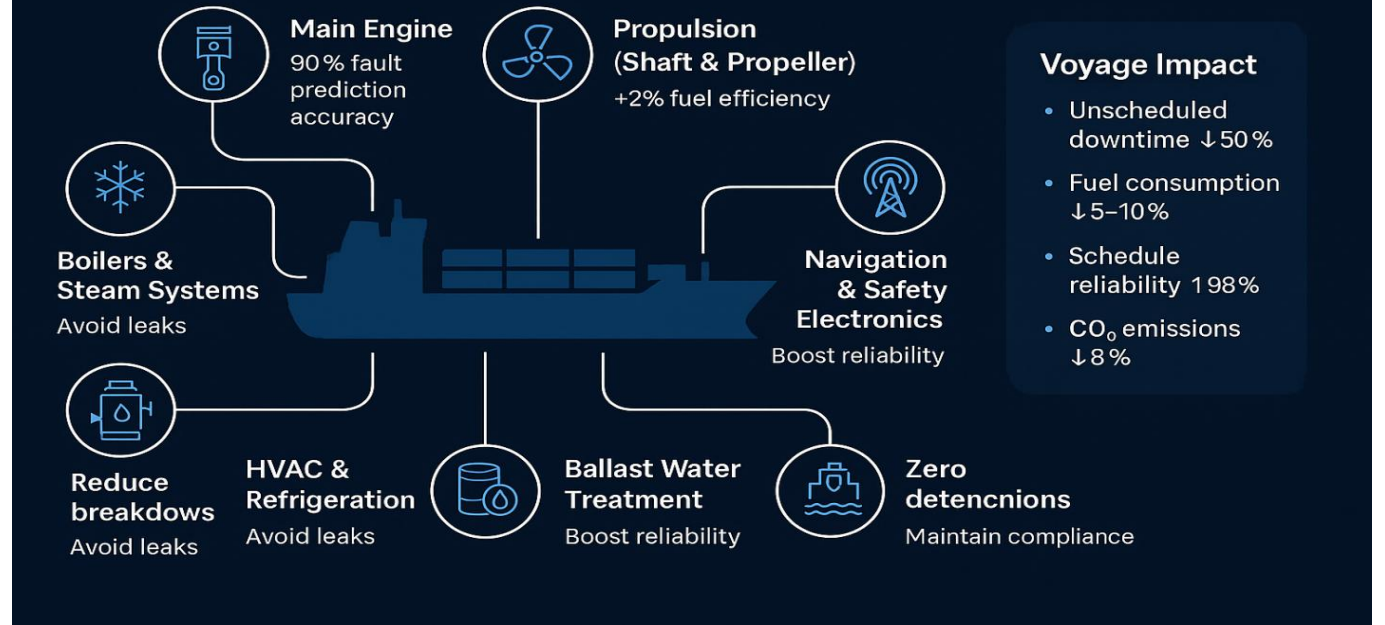



FUTURE VISION

Electrified Naval & Commercial Fleets

Strategic Direction

- Fully electrified medium vessels
- Hydrogen-electric integration
- Modular battery retrofits
- Renewable auxiliary systems

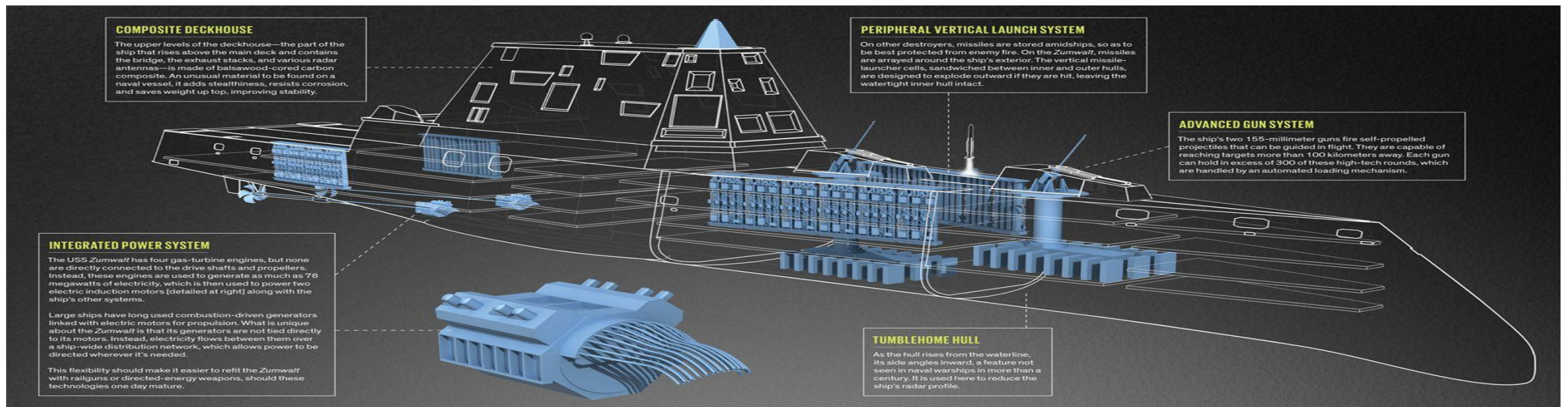



FUTURE VISION

Maritime Workforce Development

Educational Initiatives

- AI in Engineering Technology curriculum
- Distributed Generation Simulation Library
- LLM-based academic advising tools
- Industry-aligned maritime electrification labs

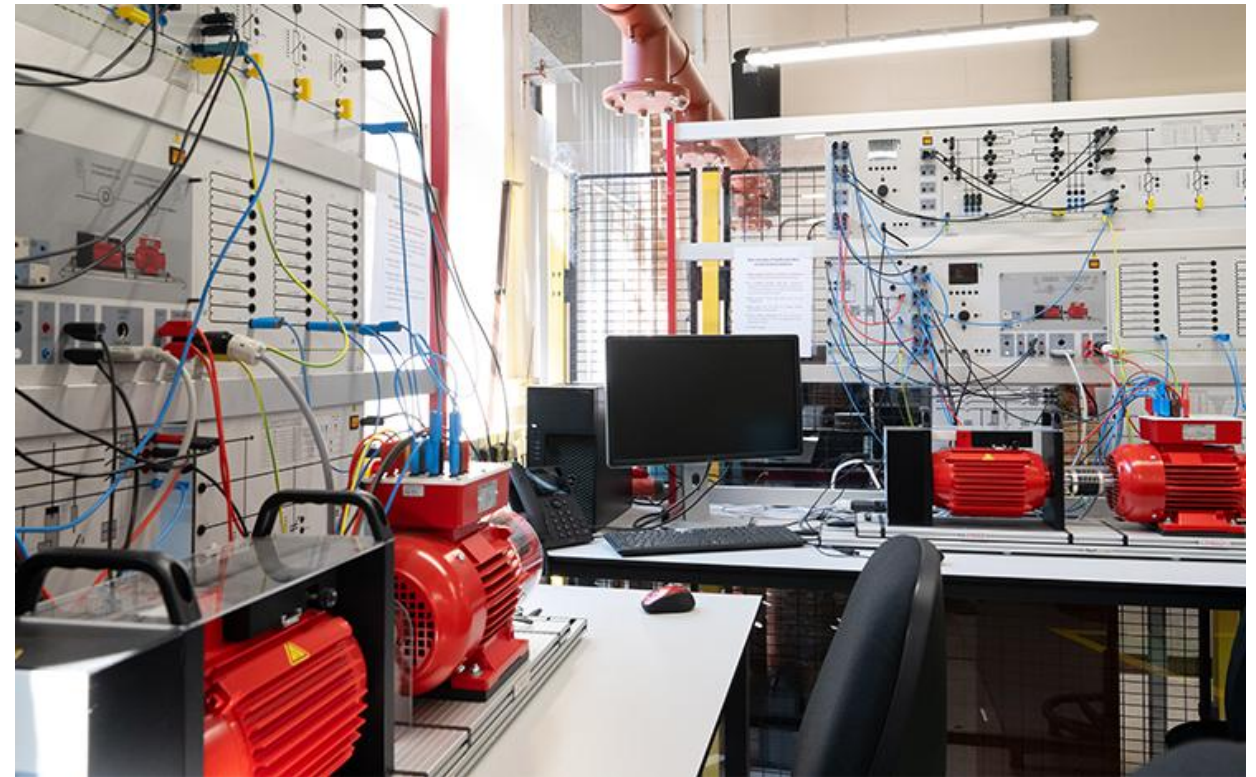

Outcome

Workforce ready for:

- Electric propulsion systems
- Shipyard electrification
- Marine DC microgrids
- Digital ship modeling





Strategic Collaboration Opportunities

Shipyards

- Hybrid retrofit modeling studies
- Energy audits & electrification roadmaps
- Predictive maintenance pilot programs

Navy & Defense

- Secure DC microgrid modeling
- Fault-tolerant propulsion validation
- Digital twin testing frameworks

Maritime Industry

- Battery lifecycle modeling
- Electrified heavy equipment systems
- Renewable shore-power optimization

Closing Vision





HAMPTON ROADS: Global Hub for MARITIME ELECTRIFICATION



Navy

- ◆ Fleet Electrification
- ◆ DC Microgrids
- ◆ Intelligent Ship Systems



Old Dominion University

- ◆ Power Systems Research
- ◆ Battery Optimization
- ◆ Digital Twin Modeling



Ship Repair Industry

- ◆ Hybrid Vessel Retrofitting
- ◆ Smart Shipyard Automation
- ◆ AI Predictive Maintenance

HAMPTON ROADS: GLOBAL HUB FOR MARITIME ELECTRIFICATION



Maritime Industry Partners

- ◆ Advanced Power Systems
- ◆ Battery Energy Storage
- ◆ AI & Digital Ship Systems





**Thank you so much
Any Questions**





OLD DOMINION
UNIVERSITY

Division of Research
and Economic Development

Virginia Digital Maritime Center

Workforce Research & Development

Dr. Jessica M Johnson



Virginia Digital Maritime Center (VDMC)

Our mission is to advance applied research and next-generation technologies to strengthen the maritime workforce, collaborative partnerships, and drive economic growth. With a forward-focused approach, we shape a sustainable maritime future for Virginia and the nation.

Our vision is to be a collaborative partner driving Virginia's maritime enterprise into the future, contributing to the resolution of Naval sustainment challenges and positioning Hampton Roads as a national standard for maritime excellence.



Technology Insertion

Integrating innovative technology into shipbuilding, repair & modernization



Digital Analytics

Applying data science and digital tools to optimize efficiency



Workforce Development

Accelerating maritime workforce education and training using emerging technologies



Powered by Research, Anchored in Innovation.



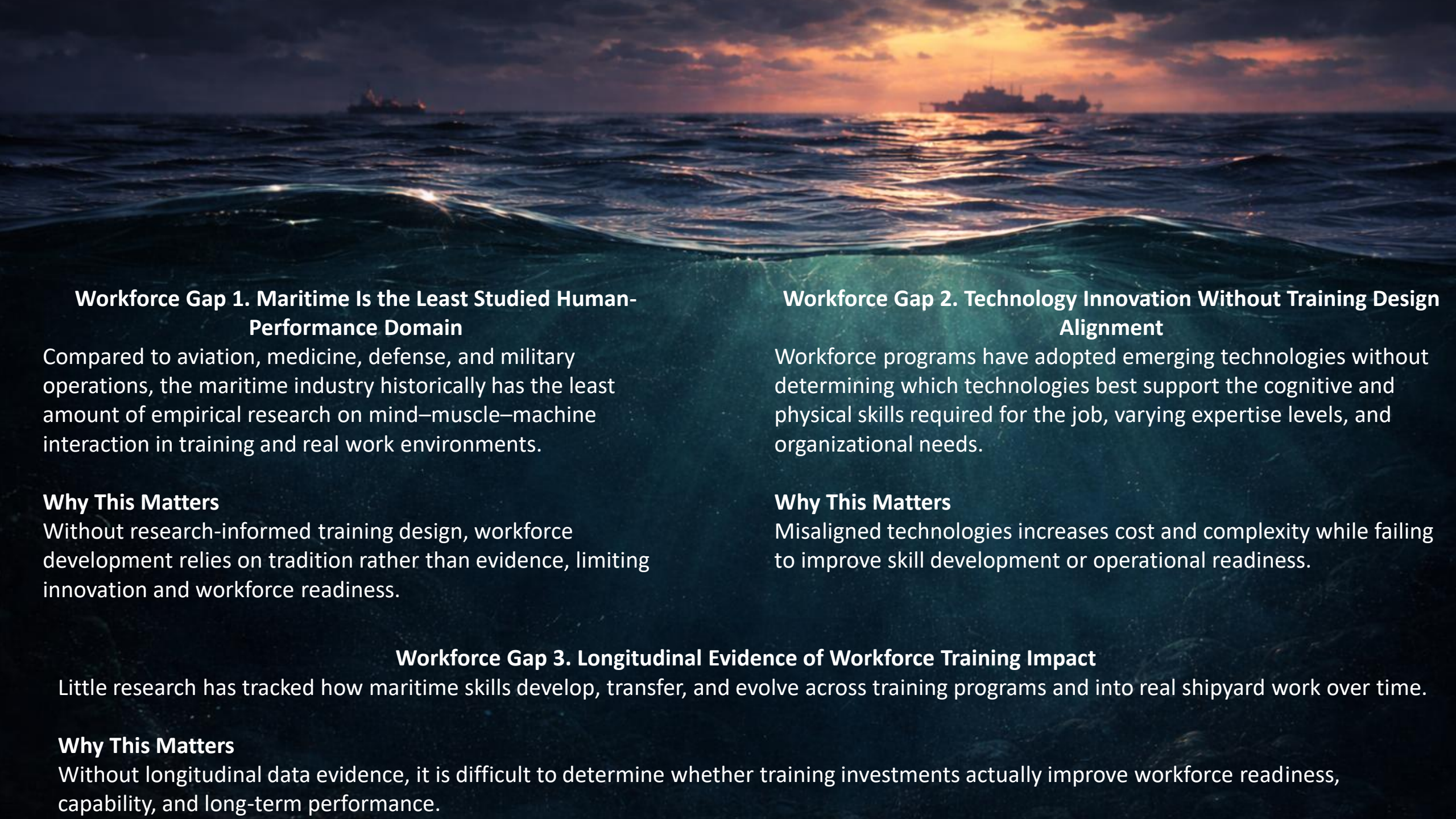

Workforce Gap 1. Maritime Is the Least Studied Human-Performance Domain

Compared to aviation, medicine, defense, and military operations, the maritime industry historically has the least amount of empirical research on mind–muscle–machine interaction in training and real work environments.

Why This Matters

Without research-informed training design, workforce development relies on tradition rather than evidence, limiting innovation and workforce readiness.

Workforce Gap 2. Technology Innovation Without Training Design Alignment

Workforce programs have adopted emerging technologies without determining which technologies best support the cognitive and physical skills required for the job, varying expertise levels, and organizational needs.

Why This Matters

Misaligned technologies increases cost and complexity while failing to improve skill development or operational readiness.

Workforce Gap 3. Longitudinal Evidence of Workforce Training Impact

Little research has tracked how maritime skills develop, transfer, and evolve across training programs and into real shipyard work over time.

Why This Matters

Without longitudinal data evidence, it is difficult to determine whether training investments actually improve workforce readiness, capability, and long-term performance.



NeuroErgo & Sim Lab

- Adaptive training environments
- Multimodal data collection



Industry Training Enhancements



K-12 Engagement



Maritime Workforce Readiness

Neuroergonomics & Simulation Lab

*Mind-Muscle-Machine
Maritime Human Performance*



Understanding Maritime Expertise Development Across the Workforce Continuum

Capture/measure gaps of how experienced maritime professionals perform complex work:

- Cognitive task analysis with subject matter experts
- Identifying decision cues, spatial reasoning, and coordination patterns
- Extracting knowledge from experienced tradespeople

Measuring Human Performance for Maritime Learning & Training

Study how knowledge becomes skill and where transfer gaps occur using multimodal sensing/data collection:

- EEG – attention and cognitive workload
- Eye tracking – spatial reasoning, information processing
- Motion tracking – Fine motor, gross motor skills
- Physiological sensing – fatigue and workload

Engineering and Validating Training Modalities

Research, test, and validate training approaches before large-scale deployment. Training modalities from no tech-high tech training resources:

- Physical mock-ups, training artifacts
- Hybrid digital–physical environments, adaptive scenarios
- Immersive simulations (360s, 3D models, AR,VR,XR)

Lab Goals:

- Investigate the cognitive architectures of maritime work for novices through transitioning workforce.
- Measure gaps between learning and real-world skill transfer.
- Identify the right training technology modality for the task, learner, trade, and organization.

VDMC Workforce R&D: Engaging the Emerging Workforce

Regional K12 Engagement Informed by Evidence-Based Research AND Industry Partner Collaborations

Expanding K12 student and educator understanding of maritime systems, technologies, and environments through applied learning experiences, immersive digital environments, and interactive instructional resources.

- Maritime Education Hub- online/web-based maritime learning resources aligned to VDOE standards
- In-classroom, after school, outreach hands-on projects and activities
- Teacher PDs
- 360 environments, 3D models, VR, AR
- High School Digital Ship Challenge

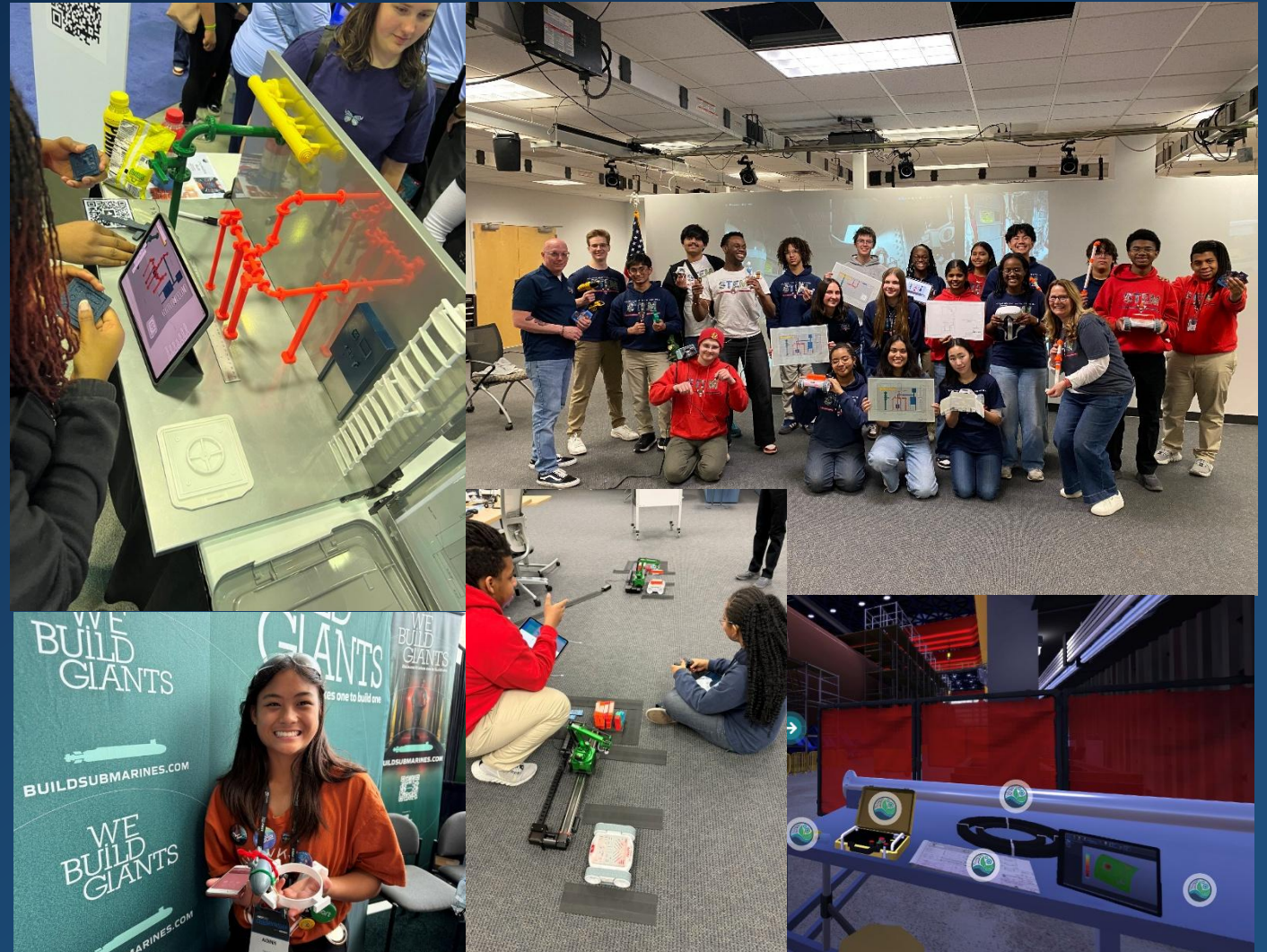

VDMC Workforce R&D: Enhancing the Current Workforce

Scale skill development through data-informed training innovations

Evaluation & Analysis

Assessments of maritime workforce systems and modalities to enhance education/training throughout the lifecycle

Assess/validate maritime workforce investments

- Infrastructure analyses
- Work analyses, content modality analyses
- Competency-alignment/development
- Technology-readiness assessments
- Technology adoption assessments
- Program evaluation

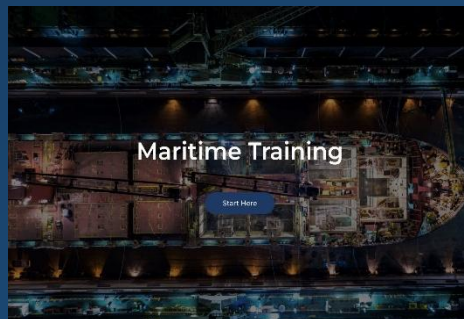
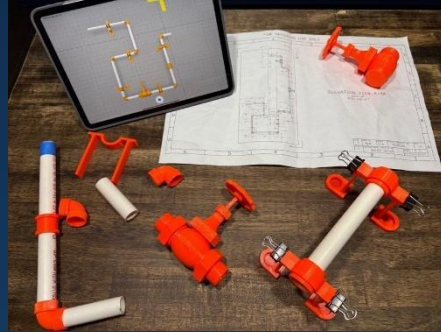

Human-Centered Design

Design and development of simulation-based content, curriculum, and resources for regional education, training, and industry partners

*Meeting partners “where they are”;
Sustainable training modality
enhancement solutions*

- Digital and non-digital training enhancements
- Simulation-based technologies: Physical training artifacts, online platforms, 3D models, 360-degree environments, mini-simulation games, VR, AR, XR

What We Are Building.

Within the Workforce R&D team at ODU VDMC we are building a human-performance maritime ecosystem to answer the following question: How do we design and validate education and training enhancements that prepare people for real maritime work throughout their lifespan?

Why This Matters.

If we understand the mind-muscle-machine architecture/interaction of maritime work we can: 1) design training modalities that accelerate acquisition of skillsets, 2) reduce costly rework and errors, 3) improve safety and productivity, and 4) strengthen the overall maritime industrial base.

The Invitation.

This work cannot happen in isolation. I/we are looking for collaborations: 1) shipyards and industry partners, 2) education and training providers, 3) ODU faculty, researchers, students, and 4) government and community leaders to study and design the next generation of maritime human performance work.

How Partners Can Collaborate: Let's Secure Funding Together!

- Collaborative research for workforce training and development
- Evaluation of training technologies
- Test simulation-based training, emerging technologies
- Participate in workforce research pilots
- Co-develop maritime K12 education resources, join the Digital Ship Challenge as mentor, sponsor



The strength of our maritime industry has never just been its ships. It's always been the people who have been trained to build/repair them and the ecosystem that supports operations.

It's time to better understand the **humans** working within them.

Dr. Jessica Johnson

Research Assistant Professor
Director- Neuroergonomics & Simulation Lab
ODU VDMC
j17johnso@odu.edu



Jennifer Renne

K12 Lead
ODU VDMC
jrenne@odu.edu



Jason Dudley

Industry Lead
ODU VDMC
j1dudley@odu.edu



John Snell

Program Manager
ODU VDMC
j1snell@odu.edu

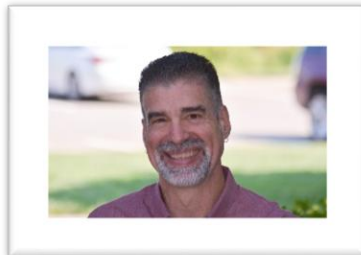

Devon Nelson

Multimedia Artist
ODU VDMC
dmnelson@odu.edu

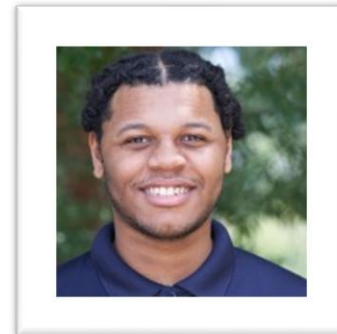

*The thrilling challenge
from the No. 1 maritime center.*

SUBS

DESIGN DIVISION **TECH DIVISION** **SYSTEMS DIVISION**

WHAT LURKS BELOW • IS THE NEXT CHALLENGE • THE DEEP IS WAITING
Coming this Spring • **DIGITAL SHIP CHALLENGE 2026** • REGISTER by **SEPTEMBER 12, 2025**
Produced by **VDMC** **IMC** MENTOR GUIDANCE SUGGESTED ORIGINAL SCREENPLAY AND ALL RIGHTS RESERVED. THIS IS A WORK IN PROGRESS. THIS IS NOT A FINAL PRODUCT. MAY BE TOO INTENSE FOR YOUNGER CHILDREN & THE UNDERPREPARED.

High School Digital Ship Challenge
April 25th, 2026

***We want more partners to collaborate with!**



OLD DOMINION
UNIVERSITY

Professional Industry Societies

Mike D'Amato
ASNE Tide Water Chapter

Benefits of Student Membership in Professional Societies

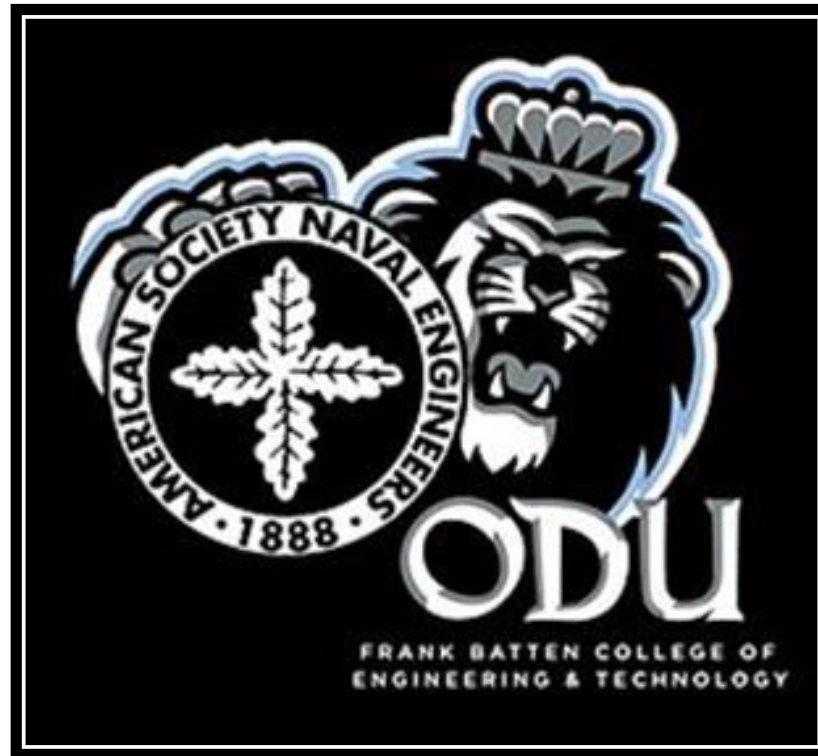

“As an engineering student, what impact can organizations like ASNE, Propeller Club and Veterans Club have on my academic and professional development?”



About ASNE...

Society founded in 1888

- 7 regional Sections
- 4 Student Chapters – ODU, USNA, Villanova, Virginia Tech
- Approximately 3,000 members

Mission:

- Advance the knowledge and practice of naval engineering
- Enhance the professionalism and well-being of members
- Promote naval engineering as a career field

Functions:

- Provide multi-discipline forums for the exchange of knowledge
- Hold symposia & technical meetings at national and local levels
- Publish technical papers in the Naval Engineers Journal (NEJ)
- Enhance professional development of members
- Recognition for significant achievements in naval engineering





Benefits of ACTIVE Membership...

- Professional Development – Listen, Learn and Engage
- Networking Opportunities
 - Meet potential employers, internships, mentors
 - Ask professionals about your field of study
 - Start building business relationships
- Academic Scholarships
- Access to 138 years “NEJ” Library & Symposia archives
- Exposure to Your Ideas... and Your NAME
 - PUBLISH technical papers
 - PRESENT at symposia
 - TALK to other students and professionals
- Be Informed... Stay Ahead of Your Peers
- Contribute to the Future of Your Profession



Start Early... Take Control of Your Future !



How do I get started?

- Participate in student chapter meetings. Leadership opportunities abound!
- Attend Dinner Meetings, Symposia and Special Events
 - Meet and hear from prominent speakers
 - Engage with professionals and potential employers
 - Learn how to network effectively
 - **Shake off the nerves before you graduate**
- Student Membership is only \$35.00 annually
- Nominal cost to attend dinner meetings and symposia
- Learn More... www.asne-tw.org
www.navalengineers.org
Talk to professionals





Upcoming Events and Symposia



PROMOTING ELECTRIC PROPULSION (PEP)

PEP National Competition: April 14-16, 2026
Portsmouth City Park (VA)



Advanced Machinery Technology Symposium
April 27-29, 2026 | Philadelphia, PA



MEGARUST
JUNE 2-4, 2026
MARRIOTT MISSION VALLEY, SAN DIEGO, CA



Multi-Agency Craft Conference 

MACC

AT THE RENAISSANCE WATERFRONT

★ ★ ★
July 14-16, 2026
Portsmouth, VA

ASNE-Sika

ULTIMATE
Build-A-Boat
CHALLENGE

FMMMS

Fleet Maintenance & Modernization Symposium



SEPTEMBER 22-24, 2026
VIRGINIA BEACH CONVENTION CENTER
VIRGINIA BEACH, VA

ASNE-Sika
ULTIMATE
Build-A-Boat
CHALLENGE

30th Annual !!
20-21 June 2026





Mike D'Amato
(757) 641-2877 / mdamato@QEDsysinc.com



OLD DOMINION
UNIVERSITY

Luncheon Speaker Mr. Jordan Webb

*President and General
Manager Colonna's Shipyard*



**COLONNA'S
SHIPYARD, INC.**

**4th Annual Maritime
Conference**

**Old Dominion
University**

March 10, 2026



Colonna's Shipyard, Inc.



- ✓ Established in 1875, **family owned and privately held**
- ✓ Small Business under NAICS Code 336611 and 336612
- ✓ **660** Full Time Employees; 96 Part-Time
- ✓ 7,500 LF of frontage on Elizabeth River with 5,000 feet of deep-water
- ✓ Over 120 acres of waterfront property 200,000 SF of industrial shop space, 1000 metric ton load-out capacity. Custom Steel Fabrication and Machining with large-scale milling and lathe capability
- ✓ Diverse Business Base:

Government: US Navy, US Coast Guard, US Army, NOAA, Military Sealift Command (MSC), US Maritime Administration (MARAD), General Service Agency, Army Corps of Engineers

Commercial: Ships, Tugs, Barges, Dredges, Ferries, Multipurpose Vessels

Industrial: Power Industry, Material Handling, Manufacturing, Infrastructure

Virginia's Maritime Economy



Port of Virginia and Maritime in Hampton Roads



- ✓ \$178.1B total port-related sales in FY 22
- ✓ Of that, \$87.8B were produced in Virginia
- ✓ **14% of total Virginia Gross Product came from Virginia goods running through the port.**
- ✓ \$59.9B of the total \$87.8B was from labor income.
 - ✓ 729,600 jobs which is approximately 20% of Virginia's non-agricultural payroll.

Information from study published by Dr. K. Scott Swan in 2023 for the VPA and VMA.

Shipbuilding and Ship Repair in Hampton Roads

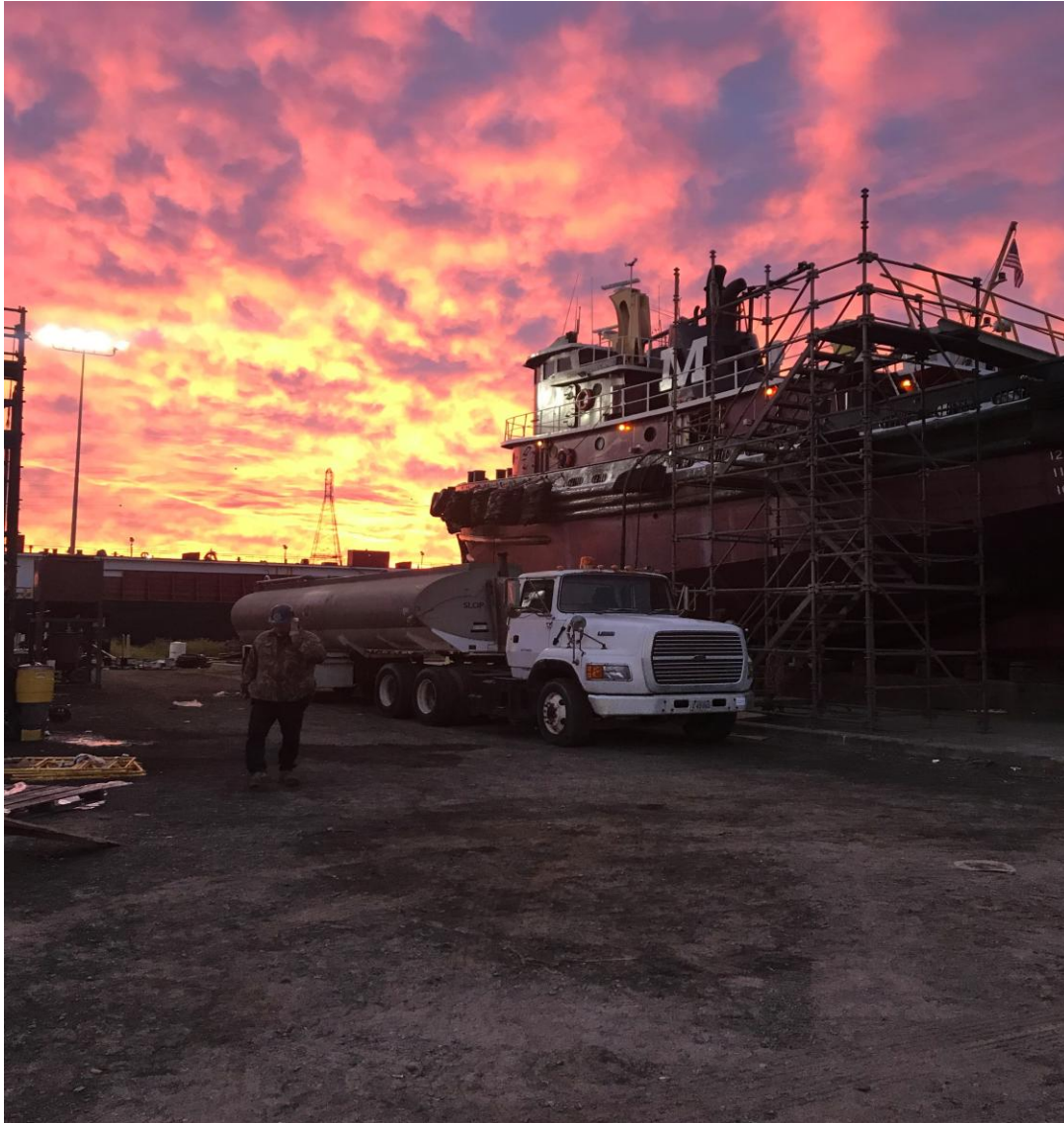

- ✓ 33,500 jobs directly in the industry
- ✓ 79,000 jobs when you consider the entirety of the supply chain.
- ✓ Virginia Ship Repair Association has over 340 member companies working in ship repair or supply to the industry
- ✓ \$10.9B in economic impact with \$6.2B in employee earning and benefits

Other than \$\$, why does it matter?

The Davidson Window

China and The Davidson Window



- ✓ China produced 39 war-ships between 2019 and 2023 with a total tonnage of 550,000 tons.
- ✓ That **increase** is 150,000 tons **larger** than the **entire** tonnage of the UK's Royal Navy
- ✓ According to published Navy data, China has 232 times more shipbuilding capacity than America.

Matthew P. Funaiolo, Brian Hart, and Aidan Powers-Riggs, Center for Strategic & International Studies, "China Dominates The Shipbuilding Industry." March 2025

Shipbuilding By the Numbers

In 2024 China State Shipbuilding Corporation built more commercial vessels by tonnage than the entire US Shipbuilding industry has since WWII.
In 2024 China built 1000 commercial vessels to the United States 8.



Source: Matthew P. Funaiolo, Brian Hart, and Aidan Powers-Riggs, Center for Strategic & International Studies, "China Dominates The Shipbuilding Industry." March 2025.

China's navy now has more ships than the US

Number of vessels in each fleet, including submarines

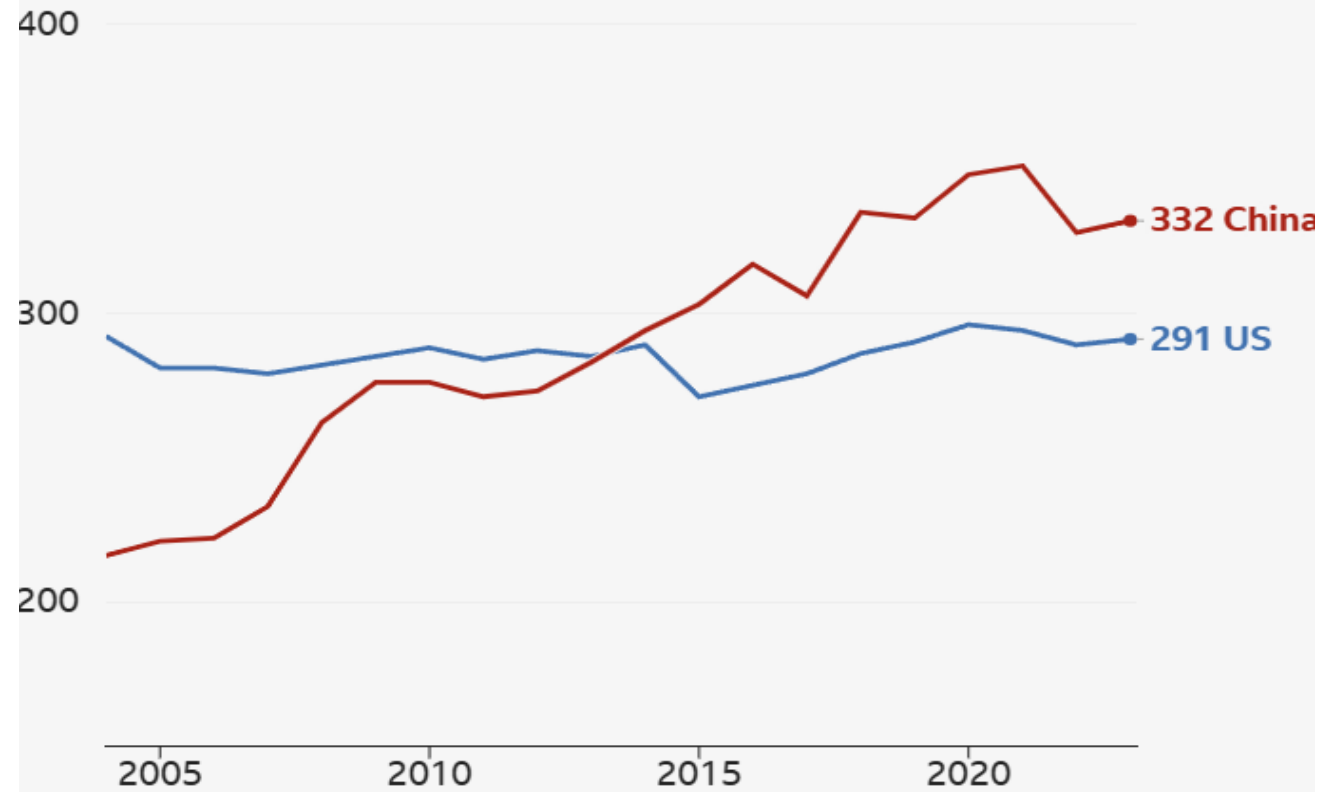

Source: US Department of Defense report, 2024



Source: bbc.com; "China's navy is expanding at breakneck speed-and catching up with the US." Laura Bicker August 31, 2025

So, what are we doing: United States Build Up

- ✓ **Executive Order: “Restoring America’s Maritime Dominance”**
 - ✓ **Required the Maritime Action Plan**
 - ✓ **Maritime Security Trust Fund**
 - ✓ **Shipbuilding Financial Incentives**
 - ✓ **Maritime Prosperity Zones**
 - ✓ **Improved Procurement Efficiency**

- ✓ **Submarine Industrial Base - Maritime Industrial Base**
 - ✓ **Workforce – over \$500M invested in workforce development funding**
 - ✓ **Infrastructure – Over \$2.4B in supplier development funding**
 - ✓ **Manufacturing Technology – Over \$200M invested in manufacturing technology**

- ✓ **2026 National Defense Authorization Act**

- ✓ **Maritime Action Plan – published in February 2026.**

As a region, what else can we do?

Workload:

1.) Use our joint power to push for an Approved budget

Continuing Resolutions have significant impacts on both shipbuilding and ship repair

- ✓ **Government Shut-downs are worse!**

2.) Contracts that are long term and not standalone with multi-year funding

- ✓ **Administration is pushing for contract reform, and it is long overdue.**
- ✓ **More stable and predictable workload.**

3.) More ships homeported or visiting Hampton Roads

- ✓ **Is Norfolk Really the Largest Navy Base? Not by the numbers**
- ✓ **More ships – commercial, USCG, NOAA, Navy, MSC – we need them all**

Norfolk Naval Ship Repair Forecast

Data as of: 12/01/2025

MARMC

FY26-FY29 Private Sector Workload Forecast with MOD estimates (no AIT) Industry Forecast - as of 01DEC2025

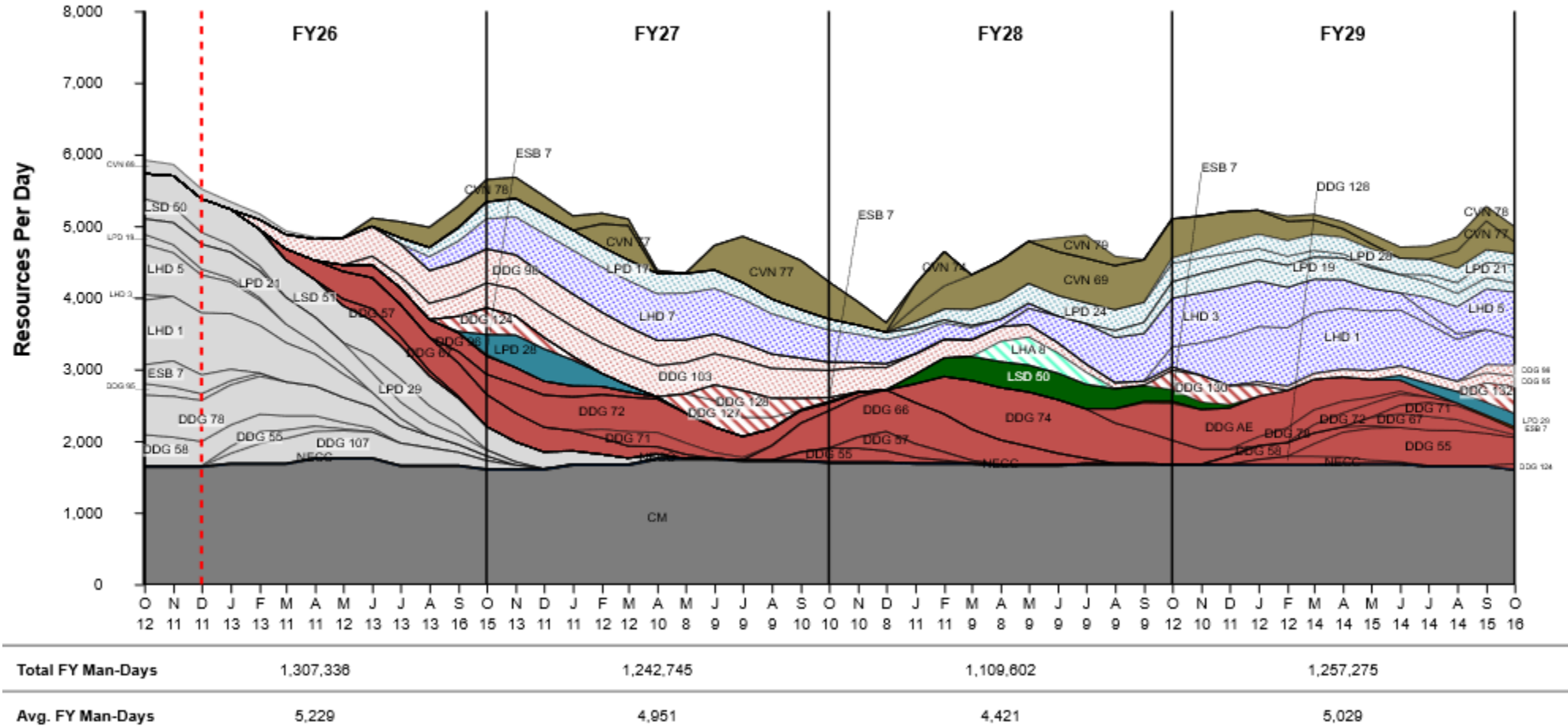

Source: Sam.gov – Private Sector Port Workload Chart published by US Navy, December 2025.

Norfolk Naval Ship Count Decline

Norfolk Navy Ship Count

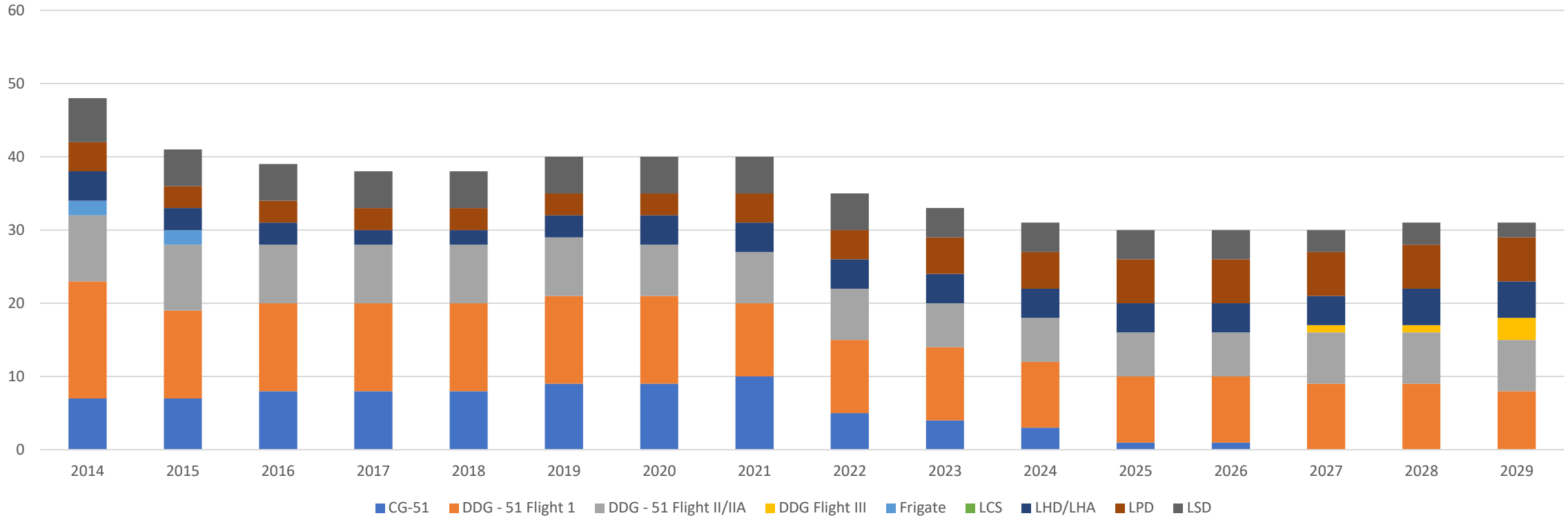

From 48 in 2014 to a projected 32 in 2029

Other Ports

San Diego Ship Count

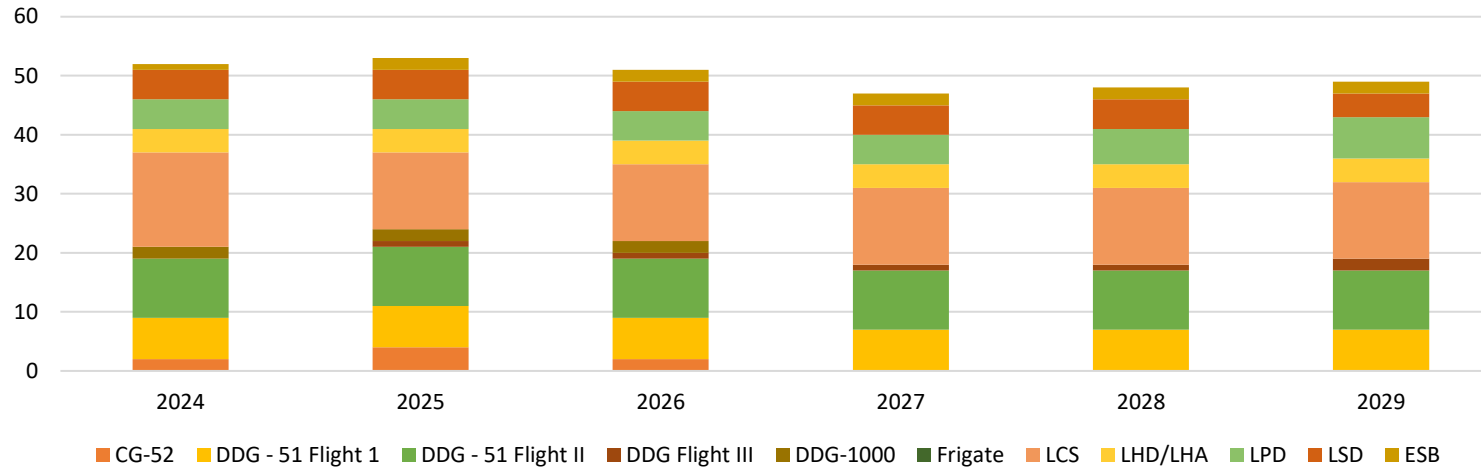

Mayport Ship Count

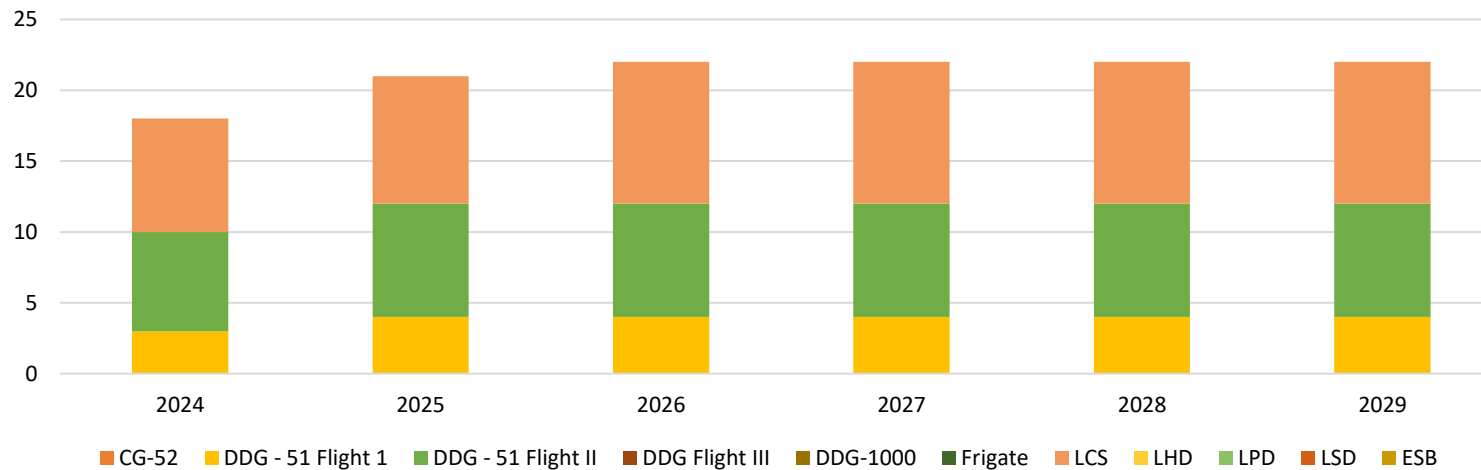

Workforce

The Good:

- **Our Workforce Pipeline is a Regional Engine** – working together reduces duplication and increases access
- **Regional Advocacy Amplifies our voices** – when we speak together, we get more results
- **Industrial Capacity is Shared Strength**– Individually we have capabilities. Together, we offer unmatched scale, depth, and resiliency that make Hampton Roads the premiere port for national defense and maritime commerce.

As a region, what else can we do?

Workforce

Opportunities:

- **Improved Regional Coordination and Workforce Branding** – We could improve alignment in our outreach campaigns, school engagement efforts, and public messaging so the region promotes maritime careers collectively – and less competitively.
- **Employer Access to Funding** – Open funding channels that allow employer-directed spending, within a preapproved framework, that can be invested in upskilling existing talent (all levels), across all trades and maritime professions, and providing wrap around services.
- **Credential Portability and Streamlined Training** – Greater regional alignment on certifications, credential recognition, and standards for educational/experience requirements would increase workforce flexibility and reduce redundancy.
- **Agency Advocacy – Build to Employer Needs** – Encourage improvements so that the voice of the employer is better recognized in the build out/updating of programs, funding opportunities, and support services. Often, changes are made that negatively impact the employers without prior awareness or consultation.

As a region, what else can we do?

Industrial Infrastructure Growth

- ✓ **How do we attract more Federal or International investment outside of Newport News Shipbuilding?**
Philadelphia (Hanwha), Austal (Hanwha & Australia) , Goose Creek, SC (HII NNS/ Keel/ Leonardo DRS), Galveston, (Davie Shipbuilding)
- ✓ **State and Local Tax incentives or credits for infrastructure investments**
- ✓ **Maritime Prosperity Region as defined in the MAP – at least at a regional level.**
- ✓ **More Local and State Grant Programs**



OLD DOMINION
UNIVERSITY

Panel I

Technology and Talent: Navigating Modern Maritime Challenges

*Moderated by Rear Admiral John Polowczyk
President, Virginia Ship Repair Association*

Paul Breitenbach, CEO R4 Technologies

*RDML Andrew Biehn, Director of Surface Ship Maintenance,
Modernization and Sustainment (SEA 21)*

Randall Crutchfield, CEO, Colonna's Shipyard

Vince Stammetti, Executive Vice President Blue Forge Alliance



OLD DOMINION
UNIVERSITY

Keynote

Mr. Matthew D. Sermon, (SES)

*Direct Reporting Program Manager
Maritime Industrial Base*



HAMPTON ROADS
MARITIME TRAINING SYSTEM

HRMTS Overview 2026



HRMETS

**Begin the Process:
Identify the Key Hub to Many Spokes**

Identify the Key Players & the Hub of the Ecosystem

**Hampton Roads
Maritime Industry**

**Regional Education
& Training Providers**

**Job-Seekers &
Candidates for
Employment**



Start to Generate Resources

The generation of resources (\$) is essential to success.
And you have to start somewhere.

In September 2020,
the Hampton Roads Workforce Council
was awarded a grant of **\$663,000**
by state funding mechanism GO Virginia
to launch the Maritime Talent Team.



HRMETS

**Data: Defining and Measuring
the Problem Before Solving It**

Data Is Critical

2022 McKinsey & Co. Projections

Bridging the projected talent gap in 2030 would require ~\$300M in funding, averaging \$37.5M per year

While \$70-90M will help close the current talent gap, demand is increasing and ~\$300M will be required to catch up and truly close the anticipated, total growing gap by 2030¹

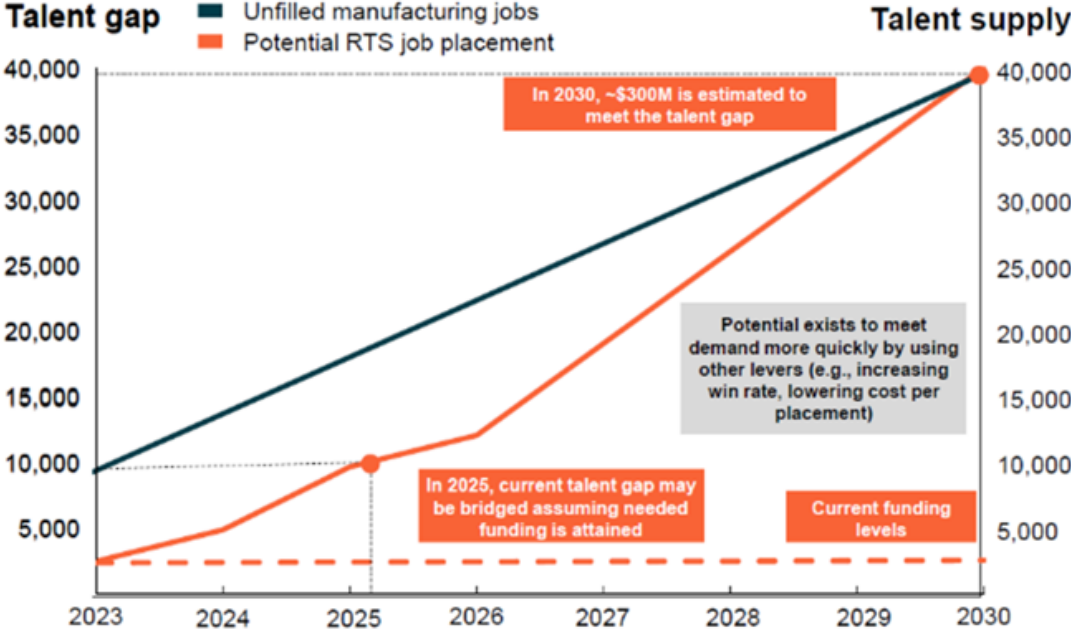

Funding needed to achieve impact	2023	2024	2025	2026	2027	2028	2029	2030
	\$18M	\$36M	\$72M	\$90M	\$142.5M	\$195M	\$247.5M	\$300M

¹. Assumes \$7,500 per placement





HRMETS

**The System: Establishing and Empowering
the Players in the Ecosystem**



HRWC Talent Pipeline Management Team Employer Collaborative

ACL	HII – Mission Technologies
AIT	HII - Newport News Shipbuilding
Amp United	IFPC
Auxiliary Systems	IMIA
BAE Systems	Mills Marine & Ship Repair
Bay Metals & Fabrication	Norfolk Naval Shipyard
Collins Machine Works	Oceaneering International
Colonna’s Shipyard	Prism Maritime
Delphinus Engineering	QED Systems
East Coast Repair & Fabrication	Standard Calibrations
Fairlead Integrated	Tabet Manufacturing
GDIT	Thermal Spray
General Dynamics NASSCO-Norfolk	Wave Force Electrical

We estimate that these 26 businesses comprise roughly 85% of the jobs needed in the regional maritime industry. We expect to add additional industry demand in the future from as much of the remaining 15% as possible.



HRWC Talent Pipeline Management Team Training Provider Collaborative

Advanced Technology Institute (ATI)	Molagik Welding Experts Training Center
Aviation Institute of Maintenance	New Horizons Regional Education Center
Bridging Communities Career & Technical Ctr	Norfolk Public Schools -- Norfolk Technical Center
Centura College	Northern Neck Training Center
Chesapeake Public Schools Career Center	Old Dominion University
Chesterfield Career and Technical Center	Paul D. Camp Community College
College of the Albemarle	QED Systems Training Center
Eastern Shore Community College	Rappahannock Community College
ECPI University	Roanoke-Chowan Community College
Halifax Community College	Rowanty Technical Center
Hampton Engineering and Robotics Academy	Southside Community College
Hampton Maritime Academy	Suffolk Public Schools – College and Career Academy
Hampton Public Schools	Tidewater Community College
Isle of Wight Public Schools	Tidewater Tech
K-Saria Fiber Optics	Virginia Beach City Public Schools
Maritime Institute	Virginia Peninsula Community College
Martin Community College	Virginia Ship Repair Association
Mid-Atlantic Academy of Trade Skills	Virginia Technical Academy

Data Is Critical

Current Supply & Demand

	Welder	Shipfitter	Pipefitter	Marine Electrician	Inside Machinist	Outside Machinist	Preservation/Coatings	NDT	Sheet Metal
Annual Collaborative Demand (~80%)	833	537	590	658	112	537	345	38	363
Estimated Regional Demand	1041	671	738	823	140	671	431	48	454
Specific Maritime Training (MTT & CTE) Capacity by Trade	2539	294	440	1754	138	325	408	0	636
Estimated Regional Deficit/Surplus	1498	-377	-298	931	-2	-346	-23	-48	182
Impact rating									



	Welder	Shipfitter	Pipefitter	Marine Electrician	Inside Machinist	Outside Machinist	Preservation/Coatings	NDT	Sheet Metal	TOTAL
Specific Maritime Training Capacity by Trade	2539	294	440	1754	138	325	408	0	636	6534



Start to Generate Resources

Based on the progress the HRWC demonstrated over the first 1-2 years of its maritime talent work, in September 2022, the Hampton Roads Workforce Council was awarded a grant of **\$11 million** by the U.S. Dept of Commerce / Economic Development Administration to expand our work and forge the Hampton Roads Maritime Training System.

HAMPTONROADS WORKFORCECOUNCIL

ONE REGION. ONE WORKFORCE. ONE ECONOMY.



Awarded \$11 million, representing 27 localities in Virginia and North Carolina

Hampton Roads ~ Eastern Shore ~ NE North Carolina



Hampton Roads Workforce Training System Supporting the Blue / Green Economy

Focus on: Regional Alignment, Talent Attraction,
Talent Development, Talent Retention, and Job
Creation

~

Over **11,000** commitments to hire

~

At least **950** jobseekers trained

~

Over **60** partners committed to participate

~

17 maritime specific workforce recruiters dedicated
to under-resourced and under-represented
communities





HRMETS

**Execution: With Proper Resourcing,
Build, Communicate, Improve**

FY23 MIB Projects

No.	Project	Cost (MM)	Funding Recipient	Category	Project Status
1.02	Virginia Beach CTE Increased Welding Capacity	\$2.5	VBCPS	Infrastructure/Capacity	Complete
1.03	Camp Community College Maritime Trades Training Facility	\$3	CCC	Infrastructure/Capacity	Complete
1.04	VA Peninsula Community College Maritime Trades Training Facility	\$4.7	VPCC	Infrastructure/Capacity	In Execution
1.05	Curriculum Alignment & Standardization	\$8	NNS/EB	Infrastructure/Capacity	In Execution
1.06a	Planning Funding: Northern Neck Technical Center Governor STEM Academy for Agriculture & Maritime Studies	\$0.3	HRWC	Infrastructure/Capacity	Complete
1.06c	Planning Funding: Roanoke-Chowan Community College Universal Technical and Training Center	\$0.3	HRWC	Infrastructure/Capacity	Complete
1.06d	Planning Funding: Martin Community College	\$0.1	HRWC	Infrastructure/Capacity	Complete
1.07	Social Media & Targeted Marketing Campaign	\$3	HRWC	Promotion/Marketing	In Execution
1.08	Incentives for Transitioning Military and Spouses	\$3	HRWC	Targeted Populations	In Execution
1.09	Expansion of the GO TEC Career Connections Program	\$2	HRWC	Student/ Parent Outreach	In Execution
1.10	Grow K-12 Outreach Programs	\$2	HRWC	Student/ Parent Outreach	In Execution
1.11	New Horizons Increased Welding Capacity - Preliminary Assessment	\$0.1	HRWC	Infrastructure/Capacity	Complete
		\$29.0			

FY24 MIB Projects

No.	Project	Cost (MM)	Funding Recipient	Category	Project Status
2.01	Trainee Achievement-Based Incentives to Reduce Barriers to Access	\$3	HRWC	Targeted Populations	In Execution
2.02	Instructors for Community College Workforce Cooperative	\$2	CCWC	Infrastructure/ Capacity	In Execution
2.05	McKinsey to Accelerate HRWC Implementation of RWTS Model	\$1	HRWC	Maritime WF Training Sys.	Complete
2.07	Tidewater Community College Skilled Trades Academy	\$3.5	TCC	Infrastructure/ Capacity	Contract Pending
2.08	Virginia Beach Renaissance Academy Lab	\$2.5	VBCPS	Infrastructure/ Capacity	In Execution
2.09	Rappahannock Community College Maritime Trades Program	\$2.5	RCC	Infrastructure/ Capacity	Contract Pending
2.12	HRWC Maritime RMTS Program Expansion	\$1	HRWC	Maritime WF Training Sys.	In Execution
2.13	Schools Harnessing Industry 4.0/5.0 Innovative Practices & Systems (SHIIPS)	\$1.5	VDMC	Student/ Parent Outreach	In Execution
2.15	Improving Government Oversight Activity for Workforce Development and Processes (SUPSHIP)	\$2	VDMC	Gov't Workforce Training	In Execution
		\$19*			

*A pair of Newport News Shipbuilding-specific projects were taken off our list early on, rendering this FY a bit lower in total

FY25 MIB Projects

No.	Project	Cost	Funding Recipient	Category	Approval Status	Contract Status
3.01	Recruitment and Attraction Expansion	\$3,000,000	HRWC	Outreach / Recruitment	Approved	Contract Pending
3.02	RMTS/HRWC Expansion and Supports/Services	\$1,500,000	HRWC	Maritime WF Training Sys.	Approved	Contract Pending
3.04	New Horizons Capacity Expansion	\$2,700,000	NHREC	Infrastructure/ Capacity	Approved	Contract Pending
3.05	Isle of Wight County Schools Capacity Expansion	\$2,000,000	IOWCS	Infrastructure/ Capacity	Approved	Contract Pending
3.06	College of the Albemarle Capacity Expansion	\$540,000	COA	Infrastructure/ Capacity	Approved	Contract Pending
3.07	Virginia Peninsula Community College	\$1,446,500	VPCC	Infrastructure/ Capacity	Approved	Contract Pending
3.08	Paul D. Camp Community College	\$1,565,000	PDCCC	Infrastructure/ Capacity	Approved	Contract Pending
3.09	Q.E.D. Systems, Inc.	\$1,985,000	QED	Infrastructure/ Capacity	Approved	Contract Pending
3.10	Funding for Maritime Training Delivery	\$4,000,000	HRWC	Workforce Training	Approved	Contract Pending
3.11	NNS Training Support for Regional Providers	\$3,000,000	NNS	Infrastructure/ Capacity	Approved	Contract Pending
3.12	Expand K-12 Maritime Immersion & Exploration Programs	\$2,000,000	HRWC	Student/ Parent Outreach	Approved	Contract Pending
3.13	Roanoke-Chowan Community College	\$520,000	R-CCC	Infrastructure/ Capacity	Approved	Contract Pending
3.14	Hampton Roads Maritime Training Academy	\$3,206,158	HRMTA	Infrastructure/ Capacity	Approved	Contract Pending

Subtotal \$27,462,658

HRMTS Investments Garnered by HRWC

- \$663k - GO Virginia – HRWC Maritime Talent Team
- \$11M - Good Jobs Challenge Grant / US Department of Commerce
- \$6.5M - Hampton Roads Strong / Commonwealth of Virginia
- \$2.5M - Norfolk Strong / City of Norfolk
- \$850k - Department of Labor / Congressman Bobby Scott Earmark
- \$714K – Woman in Skilled Careers Grant / US Department of Labor
- \$500K+ - Private Contributions / Dominion Energy, QED, Port of Virginia, others
- \$5M – Infrastructure Grant / US Department of Labor
- \$70M+ - Maritime Industrial Base / US Department of Defense

TOTAL TO DATE – over \$100M



HAMPTON ROADS
MARITIME TRAINING SYSTEM

Build the System



The HRMTS: end-to end support and service to our maritime industry's workforce needs

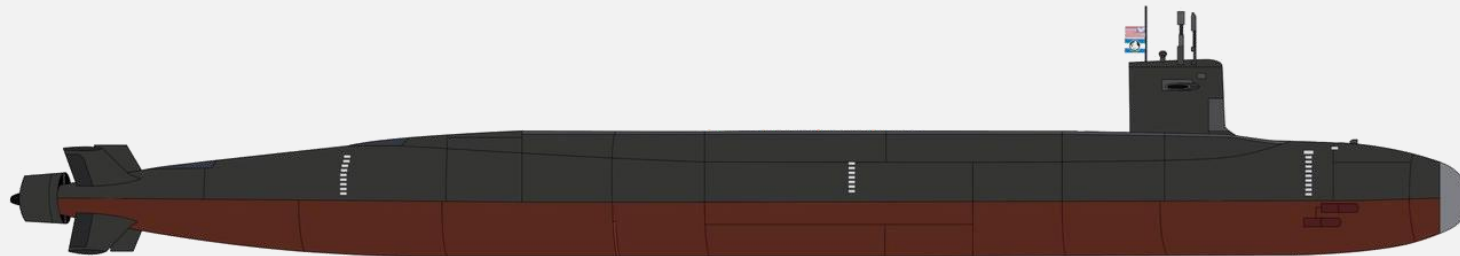

Build the System

Data & Assessment

Training Capacity

Outreach & Recruitment

Training Funding

Current Activities

- Real-Time Supply/Demand Data
- Active Employer & Training Provider Collaboratives
- Training Throughput Data
- Identify and address training capacity gaps
- Trusted Advisors to MIB on Future Workforce Projects

- Make data-driven decisions based on supply & demand
- 6 MIB Projects underway to add 2,180 trades training slots by 2026

- Dedicated recruitment and outreach to targeted communities
- HRMTS K-12 & Veterans outreach
- Recruitment campaign with marketing partners

- >\$20M in non-MIB funding since 2023
- Federal (non-DOD), state, local, & private sources

The Road Ahead

- Expand collaboratives to more employers & training providers
- Start K-12 maritime collaborative
- Expand data / ROI measurement
- Evaluate of training providers
- Single Source of Truth Dashboard on regional training

- 8 additional MIB Projects in FY25 to add another 1,500-2,000 trades training slots by 2027
- Fill all new training capacity

- Extend and expand marketing campaign
- Target right audiences via microtargeting
- Streamline and scale up K-12 and Veteran programs
- Initiate out-of-market recruitment plan

- MIB FY25 project to ensure training availability
- Pursue braided funding streams
- Increase private donations to HRMTS

Build the System

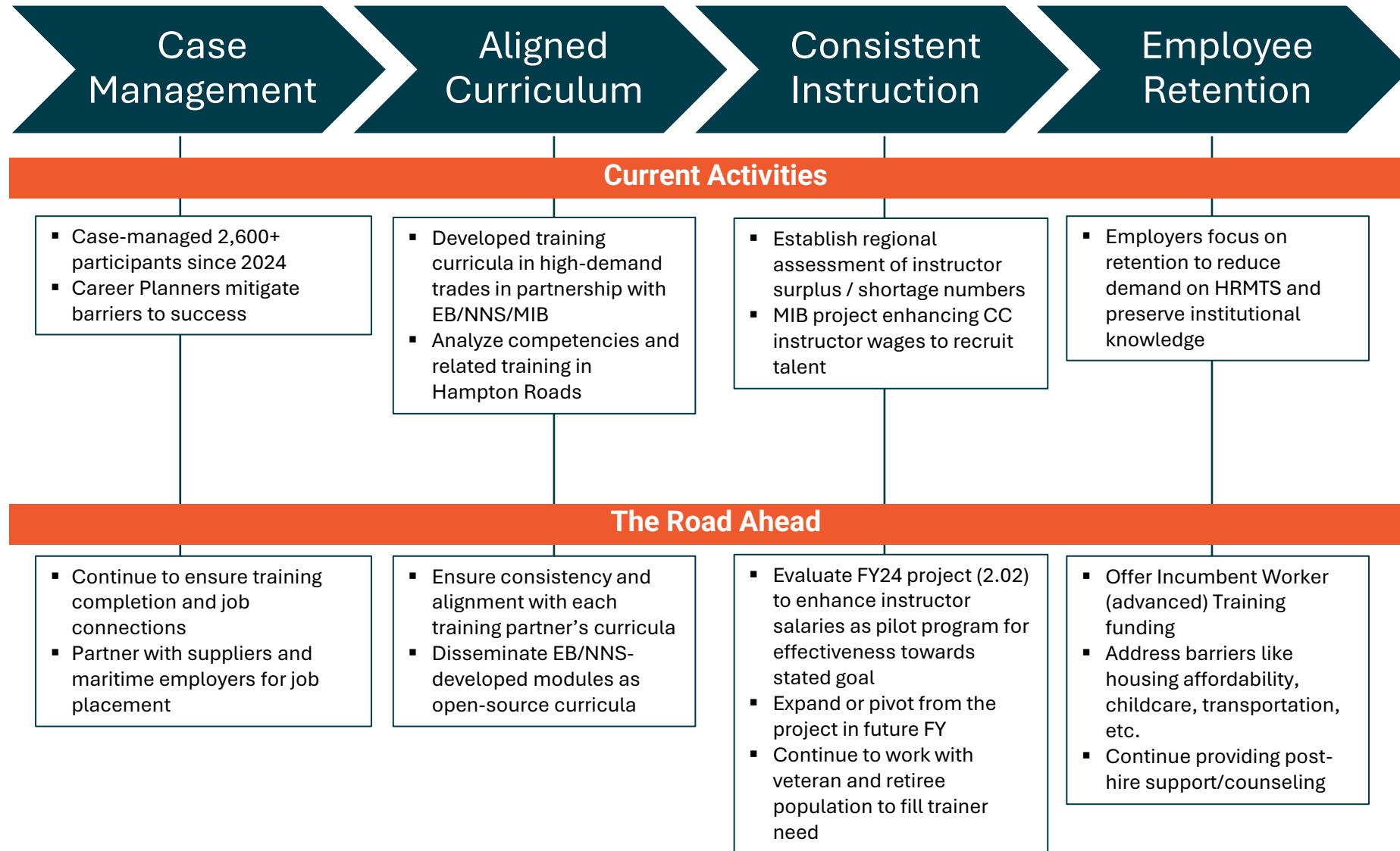



HRMETS

**More Data: The Pursuit of Real-Time Metrics
Remains a Constant**

Data Is Critical

Current Throughput

2024

	Welding	Coatings	Electrical	Inside Machinist	Pipefitting	Outside Machinist	Shipfitting	TOTAL
Enrollments	2619	217	866	30	60	312	158	4262
Completions	2360	205	828	27	57	302	149	3928
Percentage	90%	94%	96%	90%	95%	97%	94%	94%

January through June 2025

		Welding	(Marine) Electrical	Inside Machinist	Outside Machinist	Pipefitting	Shipfitting	Coatings	NDT	Sheet Metal	TOTAL
TOTAL	Enrollments	1580	516	75	56	95	4	31	0	32	2389
	Completions	1190	428	57	51	86	4	31	0	29	1876



Training Capacity Data as of September 2025

- MIB investments to date critical in closing training capacity gap.
- Future investments must prioritize specific trades with remaining gaps.

Regional Demand for Trained Workers		
5,017	4,998	5,879



Welding



Marine Electrical



Inside Machinist



Outside Machinist

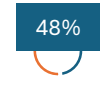

Pipefitting



Shipfitting



Coatings



NDT



Sheet Metal



■ Training Capacity
 ■ Unmet Demand
 % of Demand Met



HRMITS

Governance & Execution

2022 McKinsey & Co. Slide RE: Governance

A The Regional Training System could be led by a Governance Committee comprised of maritime employers, schools, and community advisors

Deep dive follows

PRELIMINARY

Name: Regional Training System (RTS) Governance Committee

Lead(s): Senior Director – TBD by HRWC

Mission

To build an integrated training network within a 100-mile radius of Hampton Roads that will fill the region's maritime, defense, and advanced manufacturing jobs by targeting populations from middle school through employment

Purpose

- Primary advisory board to HRWC and governing body for the RTS
- Approve annual funding strategy and initiatives list
- Build and maintain partnerships with stakeholders
- Visioning for the RTS

Potential members¹

Standing (voting): HRWC, shipbuilding member, Navy member, education member, engineering/construction member, IT/cyber member, community at large member

- Each member could have responsibility for a major function for the RTS (e.g., funding, initiatives, performance, etc.)
- Members may have term limits to allow broader representation and bring in diverse perspectives

Advisory members: VSRA, CCWC, VMA, K-12 CTE, NNSY, NNS, Fairlead, BAE, OSD, any other critical suppliers

Links to other governing or advisory groups/key interdependencies

- **HRWC Board of Directors:** Separate from the Governance Committee, Senior Director reports to CEO of HRWC
- **Partner organizations:** Support RTS initiatives and provide resources but do not take the place of voting board members on the RTS

Meeting cadence

- Meetings occur each quarter
- Funding meetings 4x year
- Performance meetings 2x year
- First meeting March 2023
- Initiatives meetings 2x year

Areas in scope

- Strategic vision
- Interfacing with larger HRWC Board, when needed
- Funding thesis and initiative strategy
- Diversification and mix of initiatives and funding

Areas out of scope

- Decisions affecting HRWC as a whole
- Final decision making for HRWC
- Assessing staffing needs
- Detailed analysis

Decisions

Organizational strategy and opportunity areas

- Diversification of funding sources
- Indirect/direct impact mix

Functional support

- Risk / reputation management
- Strategic communications
- Deepening and broadening partnership network

Strategy execution

- Performance management
- Funding goals and budgeting

Decision threshold

- >\$50K outside of annual budget
- Sets overall annual budget

How the governing group will make decisions

- Majority (51% or greater) vote by standing members to approve items

How the governing group will resolve issues

- Issues will be resolved at the lowest level possible, with unresolved disputes among Governance Committee members being elevated to the HRWC Board of Directors

1. List of advisory members is based on initial list of potential voting members from HRWC presentation to DoD on the RTS

Source: HRWC presentation on RTS, HRWC feedback

HRMTS Steering Committee Roster

As of December 2025

VOTING MEMBERS	
Representing	2026 Rep
Industry 1 (Chair)	Scott Kelley, QED
Industry 2	Tom Cosgrove, NNS
Industry 3	Nate Aiken, Fairlead
Industry 4	Ali Broemeling, Colonna's
Industry 5	John Rowe, NNSY
Industry 6	John Polowcyck, VSRA
Education 1 (CCWC)	Toni Johnson, PDCCC
Education 2 (K-12)	Marsha Cale, NHREC
Education 3	Sara Lockett, VBCPS
HRWC	Whitney Lester

NON-VOTING MEMBERS	
Representing	2026 Rep
US Navy	Erica Logan, MIB
Industry	Joe Frommelt, VSRA
Industry	Vanessa Rastberger, NNS
Industry	Robbie Walker, Marine Chemist
Industry	Nicholas Boyle, NNSY
Industry	Renee McNichol, VTPP
Education	Todd Estes, VPCC
Education	Art Hall, TCC
Education	Mark Whitney, VDMC
Education	Seth Black, Hampton PS
Education	Jorge Rivera, HRMTA
Consultant	Chip Rock, HRWC
Consultant	Courtney Culpepper, HRWC

HRMTS Steering Committee: Membership

10 voting members:

- 6 industry, to include NNS and NNSY

- 1 HRWC

- 3 training/education, to include 1 CC rep, 1 K12 rep, 1 other ed/VDMC rep

- Chair will be an industry rep

No set number of advisory (non-voting) members

HRWC: The Engine Behind the HRMTS

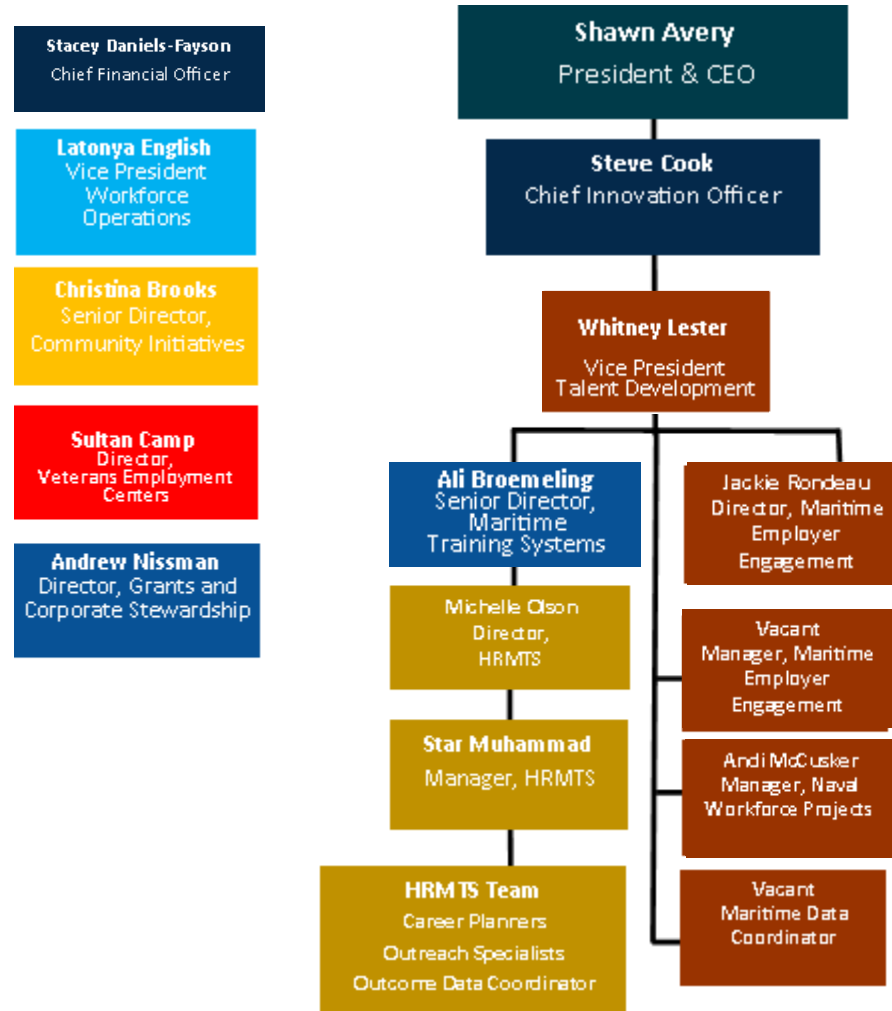

This team is growing very soon to add more Communications, Data, and other roles



HRMITS

Challenges

Maritime Workforce Challenges

To Include:

Industry

- Contracted Wage Rates for Skilled Trades Staff
- Drug Testing Barrier
- Awareness in the Regional Community
- Regulatory Issues for Ship Repair:
 - Minimum Experience Thresholds
 - Limited Visibility of Contract Futures

Training

- Tuition Funding
- Instructor Availability
- Instructor Salary Funding
- Awareness in the Regional Community

HRWC

- Data Access
- Budget for HRMTS-specific work
- Awareness in the Regional Community
- Communications



HRMITS

The Road Ahead: Continuous Improvement and Growth

2026 Priorities

To continue the leadership of HRMTS and meet the regional hiring and training demand, we prioritize the following strategies:

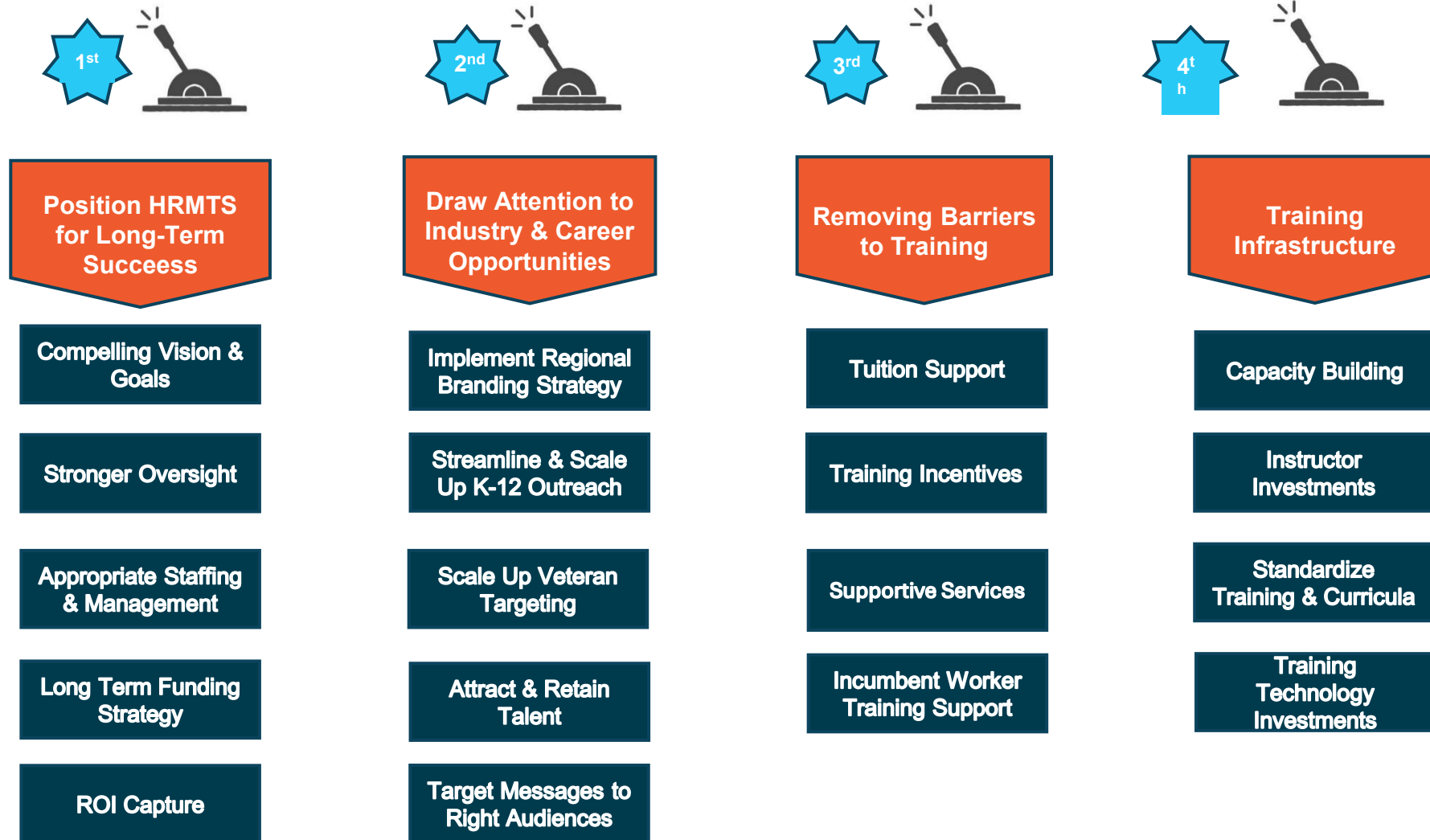



HAMPTON ROADS
MARITIME TRAINING SYSTEM

Many Thanks

HAMPTONROADS
WORKFORCECOUNCIL
ONE REGION. ONE WORKFORCE. ONE ECONOMY.



OLD DOMINION
UNIVERSITY

The Hampton Roads Playbook

Doug Smith
President and CEO
Hampton Roads
Alliance



THE HAMPTON

ROADS

PLAYBOOK

STRENGTHS DEFINED. STRATEGIES ALIGNED.



DISRUPTIVE FORCES DRIVING A NEW GLOBAL ECONOMY



Global Tensions

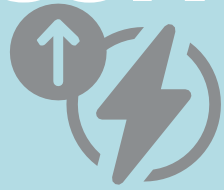

InCreaSed Energy Needs



TeCh InnOvatiOn



Federal Changes

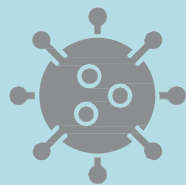

COVID PandemiC

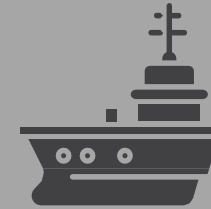

Defense Build-up

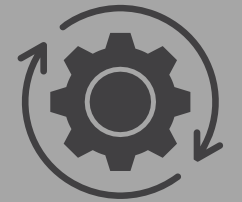

InventiOn & AdOptiOn



Digital NOmads



Energy SeCurity

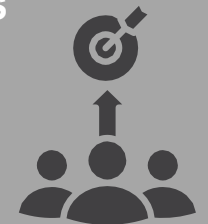

SeCtOr Alignment

AMERICA IS REMILITARIZING. RESHORING. RE-ENERGIZING.

An aerial photograph of a coastal town, likely in the Hampton Roads area. The image shows a sandy beach on the left, a lighthouse in the center, and various buildings and roads on the right. The text 'THE HAMPTON ROADS' is overlaid in yellow, and 'ADVANTAGE' is overlaid in white. The bottom of the image features a blue and yellow geometric design.

THE HAMPTON ROADS ADVANTAGE





HAMPTON ROADS,

THE SAME HARBOR THAT WELCOMED AMERICA'S EARLIEST SETTLERS IS NOW HOME TO:

- 15 diverse, dynamic communities
- 19 military installations
- World's largest naval base
- 25% of America's shipbuilding and repair capacity
- Highest concentration of active-duty military personnel outside of the Pentagon
- Deepest, widest and fastest-growing port on the East Coast
- NATO's North American Headquarters
- 2 Federal Research Labs: Jefferson Lab & NASA Langley
- 33 colleges and universities
- 3 Fortune 500 Company headquarters
- Nearly 200 international companies



FEDERAL PROCUREMENT & GRANT SPENDING

AWARDED ~\$15.5 BILLION

IN CONTRACTS AND GRANTS ANNUALLY:

5TH LARGEST METRO FOR DOD SPENDING

4-YEAR AVG, \$BILLIONS

\$13.4 BILLION (96%) FROM DOD

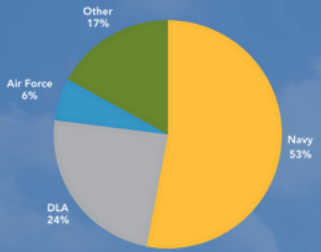

53% NAVY

SPREAD THROUGHOUT THE REGION

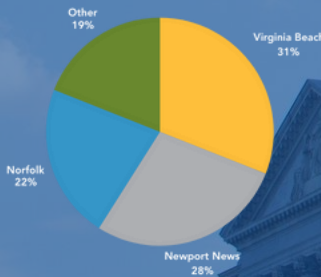

31% VIRGINIA BEACH

28% NEWPORT NEWS

22% NORFOLK

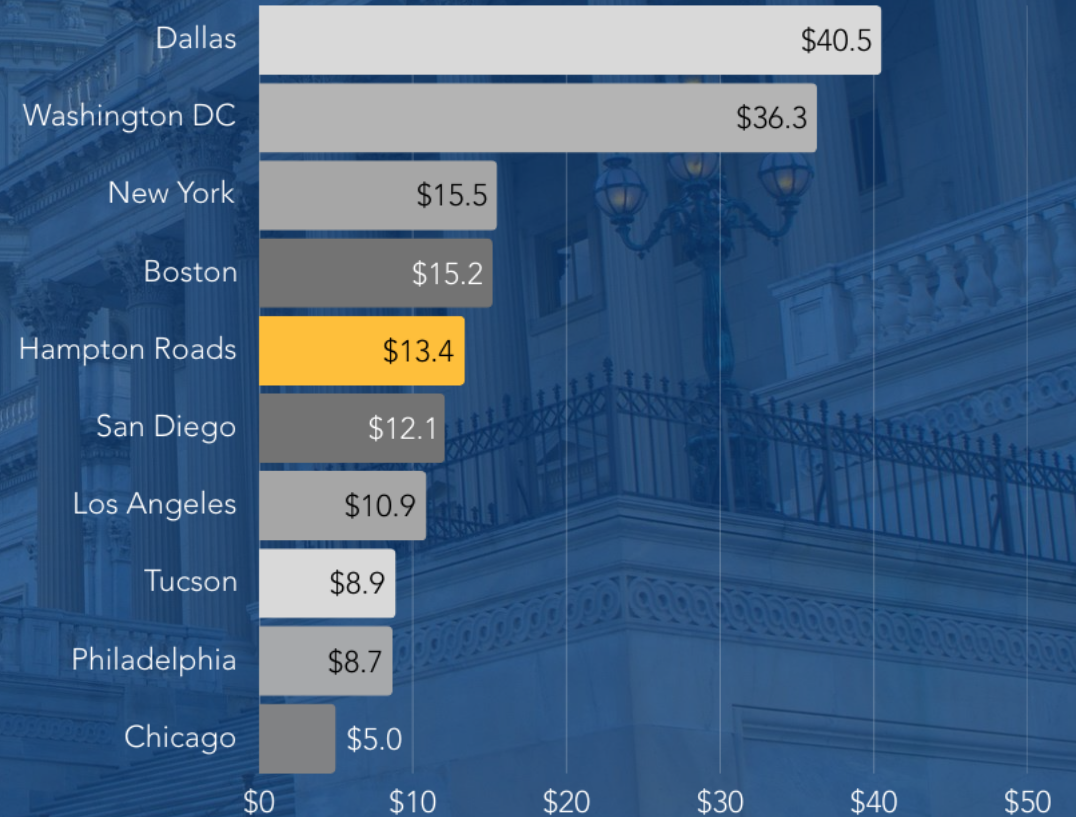

OTHER ECONOMIC CLUSTERS AND RECENT INVESTMENTS



ENERGY

Nearly \$10B for Dominion Energy's 2.6 gigawatt Costal Virginia Offshore Wind (CVOW) project

Future developments include Dominion's 800 megawatt CVOW-South project and potential 2.4 gigawatt CVOW-2 project

Hampton Roads boasts a mature nuclear ecosystem



AEROSPACE

Cutting Edge work on Uncrewed Systems, BVLOS, and AAM at NASA Langley

\$20M to expand launch capabilities and infrastructure at NASA Wallops

Rocket Lab's Neutron program to expand commercial space launches



LOGISTICS

\$1.4B to expand the Port of Virginia's capacity to be a globally significant trading hub, including:

\$50M to accomodate ultra-large container vessels

\$220M to enable staging of offshore wind turbines



THE
DEAL
FRA
MEW
ORK

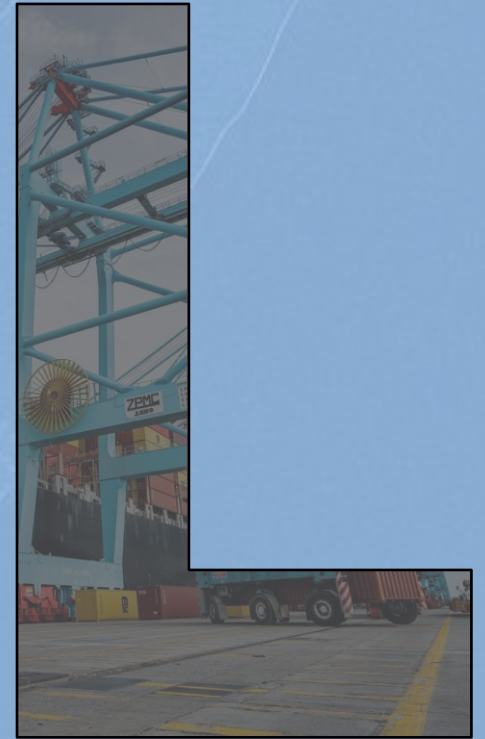
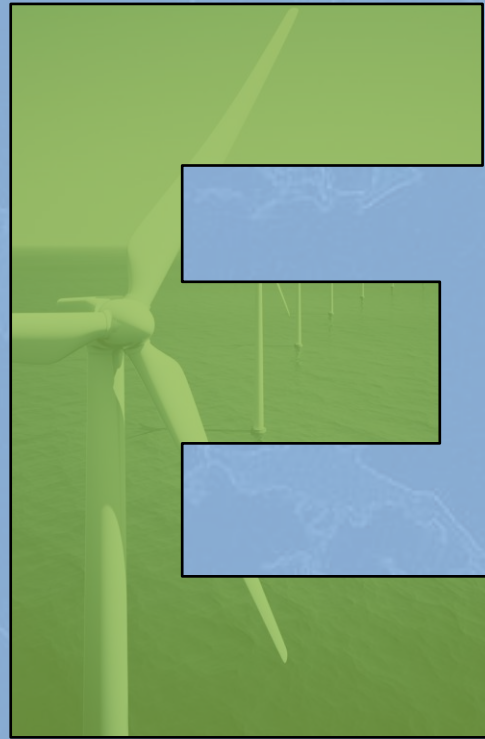

DEFENSE ENERGY AEROSPACE LOGISTICS



INDUSTRIE S & GROWTH DRIVERS



DEFENSE



ENERGY



AEROSPACE



LOGISTICS

WORKFORCE

INNOVATION & TECHNOLOGY

SITES & INFRASTRUCTURE

SUPPLY CHAIN



THE VALUE CHAIN

Hampton Roads has historically played a large role **downstream** in the value chain.



01

- Strategic research, next-gen naval concepts, disruptive tech
- Conducted in federal labs, defense innovation hubs, universities, specialized primes
- Drives long-term competitiveness
- Shapes future ship classes

Innovation



02

- Naval architecture, systems design, hull optimization, digital prototyping
- Typically concentrated in advanced design bureaus

Design & Manufacturing

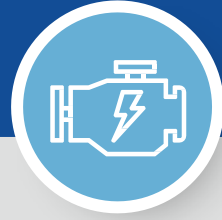

03

- Engines, propulsion, HVAC, electronics, sensors, weapons, other systems
- Often produced by specialized Tier 1 and 2 suppliers, sometimes internationally

Component & Subsystem Manufacturing



04

- Cutting steel, assembling hull sections or superstructure modules
- Labor- and capital- intensive; heavily influenced by robotics and shipyard layout

Modular Fabrication



05

- Integrating modules, installing systems, completing interiors
- High employment impact but lower innovation capture

Final Assembly & Outfitting



06

- Sea trials, systems verification, delivery to Navy or customer
- Often done by lead shipyards or government

Testing & Commissioning



07

- MRO (maintenance, repair, overhaul), digital twins, tech upgrades
- Recurring revenue; increasingly data- and tech- driven

Life Cycle Support & Modernization

Historical strength of Hampton Roads





TRANSFORMATIVE PROJECTS



TRANSFO RMATIVE PROJECTS

AUKUS Center
Of ExCellenCe



SeCure Energy
Future Center



NEXUS: NatiOnal
ExCellenCe in
UnCrewed Systems



ElizaBeth RiVer
Dredging



HamptOn ROads
AmbassadOr
COrps



757 COllab Defense
TeChnOIogy
ACCeleratOr



HamptOn ROads
Maritime Training
System (HRMTS)



Defense
EffiCienCy &
PrOduCtiOn Center



**P
R
O
J
E
C
T
L
E
A
D
S**

Kathryn H. Floyd
William & Mary

Chelsea Olivieri
VTCRC
@ Tech Center
Research Park

Nancy Grden
Hampton Roads
Executive
Roundtable

David White
Virginia Maritime
Association

**Rear Admiral
(ret). Chip Rock**
Hampton Roads
Alliance

**Paul Nolde
& Kali Luthre**
757 Collab

Shawn Avery
Hampton Roads
Workforce Council

Doug Smith
Hampton Roads
Alliance



FUTURE CONSIDERATIONS

The Playbook is a living document.

Get involved and help it grow.

GROWTH DRIVERS

- Housing Availability & Affordability

INDUSTRIES

- Innovation Commercialization
- Coastal Resiliency
- Blue Technology
- Digital Infrastructure & Cybersecurity
- Healthcare & Biosciences
- Tourism



VISIT THE PLAYBOOK PORTAL

HAMPTONROADSPLAYBOOK.COM

TOOLS TO Get Engaged:

- Regional Asset Map
- Bruce Katz'S Diagnostic
- Constellation Posters
- Videos

COMING SOON:

- Unabridged Playbook
- Project White Papers
- Defense Capabilities Matrix

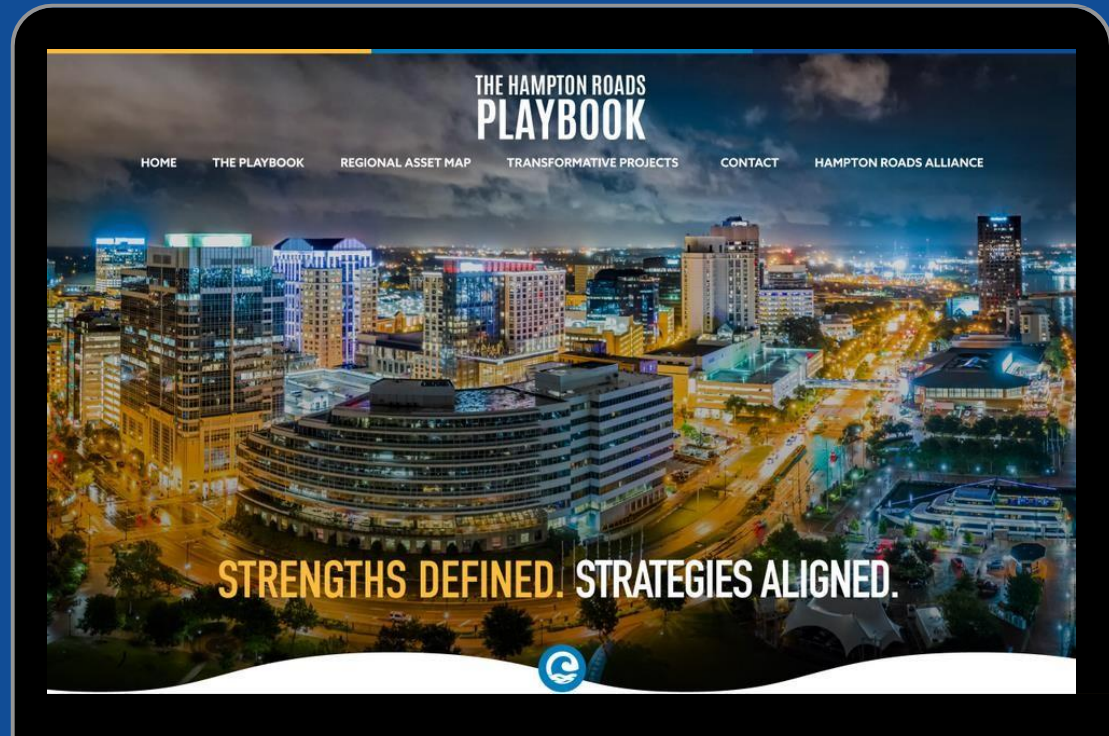

THE HAMPTON ROADS

PLAYBOOK

STRENGTHS DEFINED. STRATEGIES ALIGNED.

LOOK

IT'S **GO** TIME.

HAMPTON ROADS
ALLIANCE 



OLD DOMINION
UNIVERSITY

Panel II

Strengthening Supplier Success: People, Performance and Partnerships

Moderated by Mr. John Rhatigan

Chairman of the Board, Marine Machinery Association

Fred Pasquine, President, Fairlead

*William Berger, Ex. Dir. Strategic Accounts, Fairbanks Morse
Defense*

Bill Guglielmo, President, ITL Solutions



OLD DOMINION
UNIVERSITY

Closing Remarks

Elspeth McMahon, PhD
Associate Vice President for Maritime Initiatives

odu.edu/maritime